

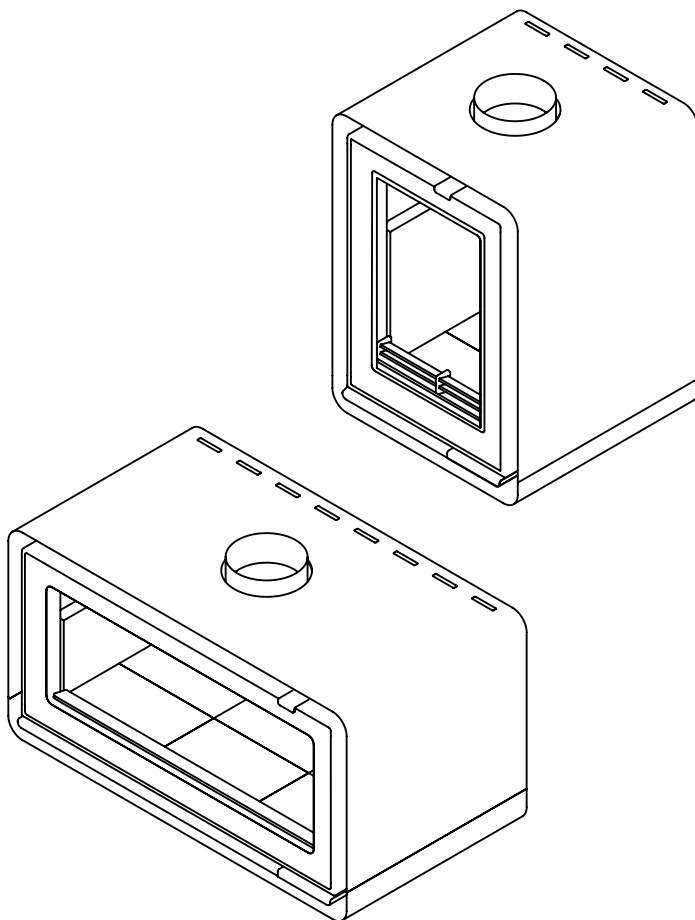

KALORA

URBAN RANGE

USER MANUAL



SERIES

Urban LS

SG010100006

Urban PT

SG010100016

Kalora Pty Ltd

Head Office
58 Access Way
Carrum Downs VIC 3201
Australia

+61 3 8579 5905
info@kalora.com.au
www.kalora.com.au

Version 1.6

Contents of manual may be updated without notice.
For the latest version of this manual please refer to our website: www.kalora.com.au

KALORA URBAN HEATER RANGE

Model Name	Model Number
Urban LS (Wood Fire only)	SG010100006
Urban PT (Wood Fire only)	SG010100016

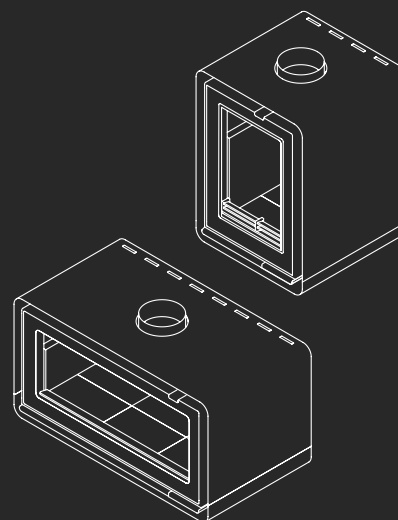

Wood heater safety	2
Before installing your wood heater	3
Unit dimensions	4
Firebox assembly	6
Installation	7
Operating your wood heater	17
Wood heater maintenance	19
Troubleshooting	21
Warranty	23
Spare parts list	25
Warranty Registration Card	29

INTRODUCTION

Congratulations on purchasing a genuine Kalora wood heater. When cared for properly, these high quality, finely crafted wood heaters will offer many years of reliable performance. This instruction manual has been developed to ensure optimum performance from your Kalora wood heater. It's very important that you thoroughly read and understand all instructions before using your new wood heater.

COUNCIL REQUIREMENTS

Check Local Council Requirements Eg. permits

When installing, operating and maintaining your wood heater, follow the guidelines presented in these instructions, and make them available to anyone using or servicing the wood heater.

Your city, town, state or territory may require a building permit to install a solid fuel burning appliance.

Always consult your local building inspector or local council to determine what regulations apply in your area.



WARNING! Important information

Your wood heater must be installed by a qualified person whose work conforms with local council regulations, Australian standards & manufacturers recommendations. Failure to do so will void your warranty and could possibly void any home insurance.



CAUTION! Important Information

WOOD HEATER SAFETY

When properly maintained and operated your wood heater should give you many years of service, however there are important safety aspects of these products that you need to be aware of when operating a wood heater.

1. This appliance is not intended for use by persons (including children) with reduced physical, sensory or mental capabilities, or lack of experience and knowledge, unless they have been given supervision or instruction concerning use of the appliance by a person responsible for their safety.
2. Children should be supervised to ensure that they do not play with the appliance.
3. Never place combustible items such as but not limited to furniture, fabric or wood within the specified clearances to combustibles.
4. The burning of wood gives off gases which can be extremely dangerous. Wood heaters are designed so that under normal operating circumstances these gases pass up the flue chimney system and cannot escape into your home, however it is important that your flue system is properly installed and that you check all joints regularly to ensure that there are no cracks or gaps, check the door sealing rope and replace when damaged/worn. We recommend a smoke alarm be fitted in rooms where wood heaters are installed. Do not use your wood heater in a room where negative pressure conditions exist. Negative pressure environments can cause products of combustion to be drawn from the fireplace into the room. Caution should be taken when using any form of extraction in a room where a wood heater is installed.
5. This appliance is designed to specifically burn dry hardwood. Do not burn rubbish, driftwood, flammable liquids or any substance containing salts or corrosives.
6. Creosote and soot may accumulate in your flue pipe and chimney. This may ignite, causing a chimney fire. If you suspect a chimney fire close down the air controls on the wood heater, if the fire persists evacuate people from the building and call the Fire Brigade. To prevent the accumulation of soot or creosote, check flue and chimney regularly and clean as necessary. Good burning, hot wood heaters will generally cause a lot less build-up than slow burning wood heaters, likewise dry wood will cause less build-up than wet wood. We recommend a fire extinguisher be available where wood heaters are in operation. In the event of a chimney fire do not re-light the wood heater until the heater and the flue chimney system have been thoroughly checked and repaired/replaced as necessary.
7. Wood heaters get extremely hot and should not be touched when lit. When young children are in the area, we recommend the use of a suitable fire guard around the wood heater. Always wear protective gloves when reloading wood heater.
8. Never over-fire your wood heater. If external parts of your wood heater are glowing red then the wood heater is over-firing and your draught settings should be reduced. Never interfere with the draught mechanisms or adjust your air settings outside those limits set when the wood heater is manufactured. Never use a secondary fan to supply or extract air to the wood heater.
9. All users of the wood heater should be aware of the contents of this manual. Please leave this manual where it is accessible to wood heater users and do not allow anyone to use the wood heater that is unfamiliar with its correct operation.
10. Never use the wood heater if any parts are missing or damaged, only use genuine parts as replacements.
Never modify your wood heater.

BEFORE INSTALLING YOUR WOOD HEATER

You need to consider the following to ensure the safe operation of your wood heater:

- Provision of adequate air to support efficient combustion of the fuel.
- A well sealed flue/chimney system, hereinafter referred to as the “flue system”.
- The protection of combustible materials in proximity of the wood heater.
- A suitable base on which to place your wood heater.

ADEQUATE PROVISION AIR

It is essential for the safe and efficient use of your wood heater that you provide an adequate air supply to your wood heater.

This may mean the provision of an outside air supply to the room, especially if there are extraction units such as cooker hoods or clothes dryers in the vicinity. Failure to do so will mean that fuel is burned inefficiently causing smoke, blackening the glass and may also cause smoke to come back into the room. As a simple check for this open a door or window in the room and check if the wood heater burns more efficiently.

WELL SEALED FLUE SYSTEM

Under no circumstances should you use aluminum or galvanized steel active pipes for your wood heater flue. Always fit active pipes with the narrow crimped side down, this allows any creosote to run down the inside of the pipe and not to come out and cause an unsightly mess and possible fire hazard.

Pipe bends should be kept to a minimum and we do not recommend using more than 2 bends on any installation. Flues must not pass through ceilings, floors, attics, roofs, or combustible walls without adequate and approved insulation being provided to protect combustible materials.

The chimney and flue provide a means of taking combusted fuel from the wood heater, as well as a draught to enable the wood heater to work. It is essential that the flue system is kept in good condition and there are no breaks or cracks allowing contact with any other combustible materials of the house. It is also essential that the flue system is kept clean and seals are maintained to ensure the draught is not lost.

The open end of the flue system must be above the height of the apex of the building and any other obstructions, such as trees, which are within 3 meters (10ft) of the flue system. Failure to do this will affect the efficiency of the wood heater and may cause down draughts which will mean dangerous products of combustion are emitted into the room.

Under no circumstances should the flue pipe be less than 6” (152mm) internal diameter.

CLEARANCES TO COMBUSTIBLES

It is extremely important that you respect required installation distances and that you respect local installation regulations.

This is for your safety! The manufacturer is not responsible for the product, if it is not installed following these recommendations. These clearances may only be reduced by means approved by the regulatory authority.

A combustible surface is anything that can burn (i.e. plaster, wall paper, wood, fabrics etc.) These surfaces are not limited to those that are visible and also include materials that are behind non-combustible materials. If you are not sure of the combustible nature of a material, consult your local fire officials.

It is the responsibility of the purchaser and installer to ensure all finishes (including but not limited to render, paint, tiles, stone and other wall finishes) near and around the fireplace have the capacity to withstand high temperatures. Kalora Pty Ltd cannot be held responsible/liable for thermal expansion, cracking, blistering or damaging of any finishing materials.

UNIT DIMENSIONS

HEATER

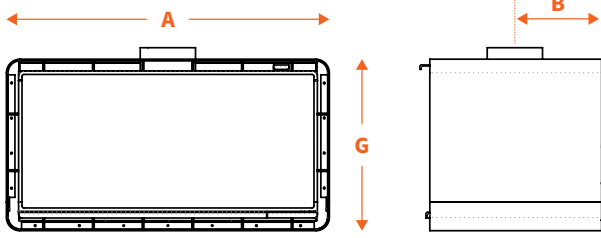

URBAN LS (FRONT/SIDE)

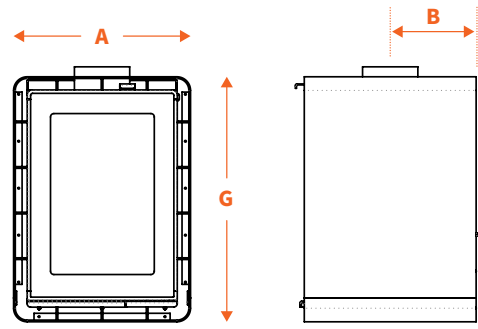

URBAN PT (FRONT/SIDE)

HEATER WITH ACCESSORIES

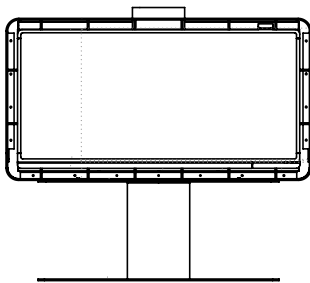

URBAN LS WITH STAND

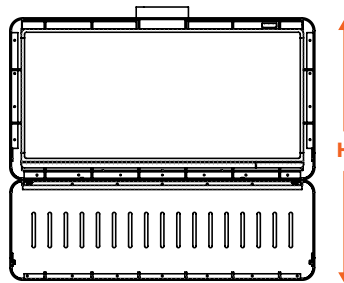

URBAN LS WITH WOOD STORAGE

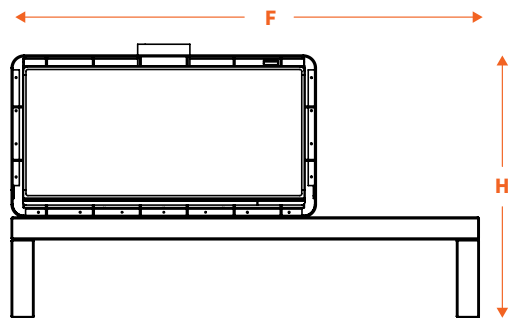

URBAN LS WITH PLINTH

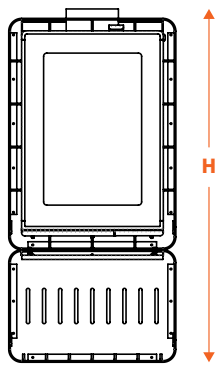

URBAN PT WITH WOOD STORAGE

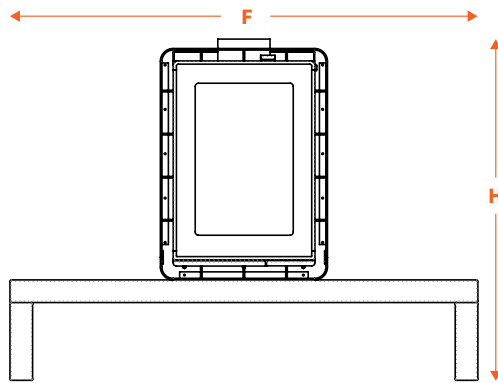

URBAN PT WITH PLINTH

INBUILT HEATER (WITH ZERO CLEARANCE BOX)

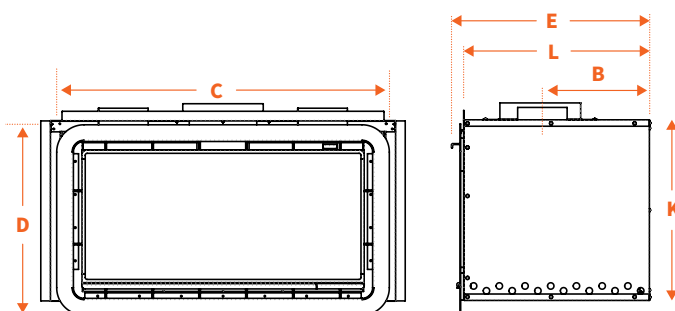

URBAN LS (FRONT / SIDE)

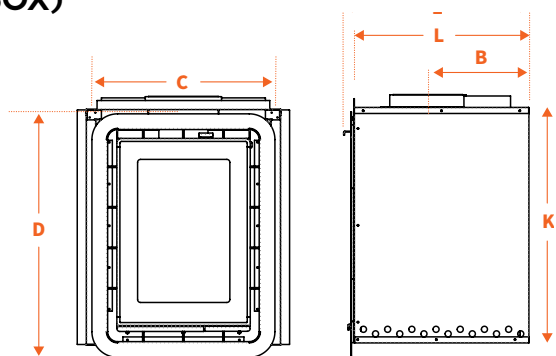

URBAN PT (FRONT / SIDE)

UNIT DIMENSIONS....continued

INBUILT ZERO CLEARANCE BOX

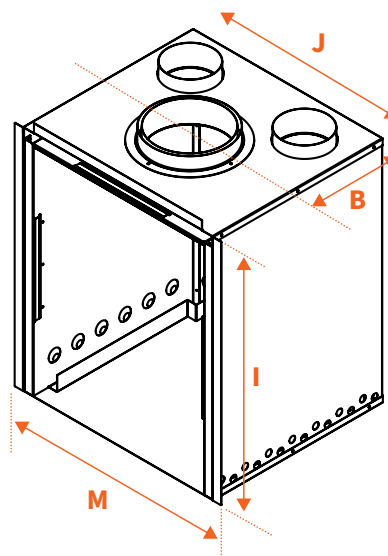
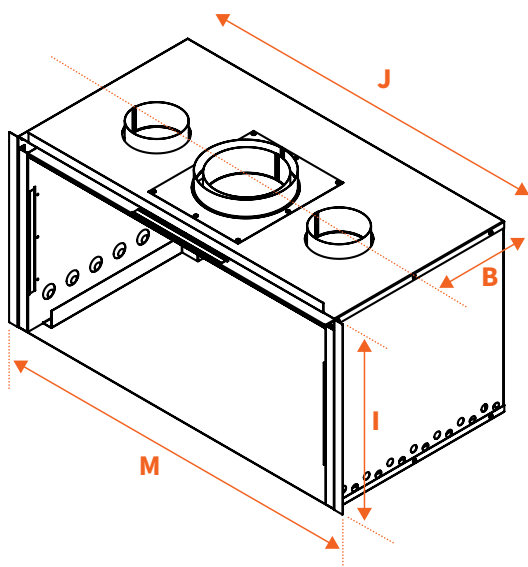

		URBAN LS	URBAN PT	URBAN LS ZCB	URBAN PT ZCB
Inbuilt Heater					
A	Firebox casing width	949	520		
B	Rear of firebox casing to centre of spigot	250	253	336	335
C	Floor mount fascia width			1035	605
D	Mid mount fascia height			592	805
E	Depth overall (including fascia and handle)			617	614
G	Firebox casing height	504	720		
Freestanding Heater					
F	Urban LS/PT on Plinth	1456	1456		
H	Firebox case height with accessories	816	1032		
Clearance Box					
I	Height of clearance box front			591	807
J	Zero clearance box casing width			1078	646
K	Zero clearance box casing height			592	779
L	Depth of clearance box			579	579
M	Width of clearance box front			1134	702

All measurements are in 'mm'

FIREBOX ASSEMBLY

FIREBRICKS

REMOVAL

1. Remove firebrick retainers
2. Remove rear firebricks
3. Remove side firebricks
4. Remove base firebricks

INSTALLATION

1. Install side firebricks
2. Install rear firebricks
3. Install firebrick retainers
4. Install base firebricks

BAFFLE

REMOVAL

Caution: Wood heater baffles can be heavy. It may be best to have an experienced wood heater installer perform this task.

1. Remove firebricks. Refer to 'REMOVAL' in 'FIREBRICKS'
2. Place both hands under the baffle and lift the baffle upwards approximately 20mm
3. Move the baffle towards the firebox door, just enough to clear the rear locating lugs
4. Tilt the baffle so that the back of the baffle is under the rear locating lugs and the front of the baffle is clear of the front locating lugs
5. Lower the baffle to the floor of the firebox
6. Rotate the baffle almost 90 degrees from its normal resting position and remove the baffle from the firebox

URBAN LS - FIRE BRICKS

1. Top Baffle - Qty 2
2. Vermiculite Side Liner - Qty 2
3. Vermiculite Base Liner - Qty 4
4. Vermiculite Rear Liner - Qty 1
5. Vermiculite Retainer - Qty 2

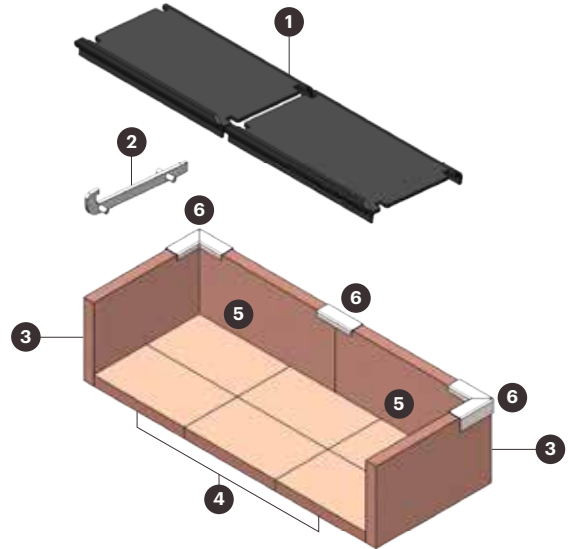

URBAN PT - FIRE BRICKS

1. Top Baffle - Qty 3
2. Vermiculite Side Liner - Qty 1
3. Vermiculite Base Liner - Qty 6
4. Vermiculite Rear Liner - Qty 2
5. Vermiculite Retainer - Qty 3

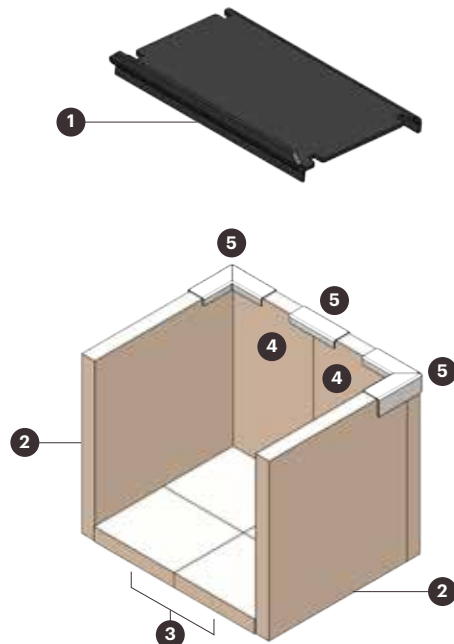

INSTALLATION

MINIMUM INSTALLATION CLEARANCES

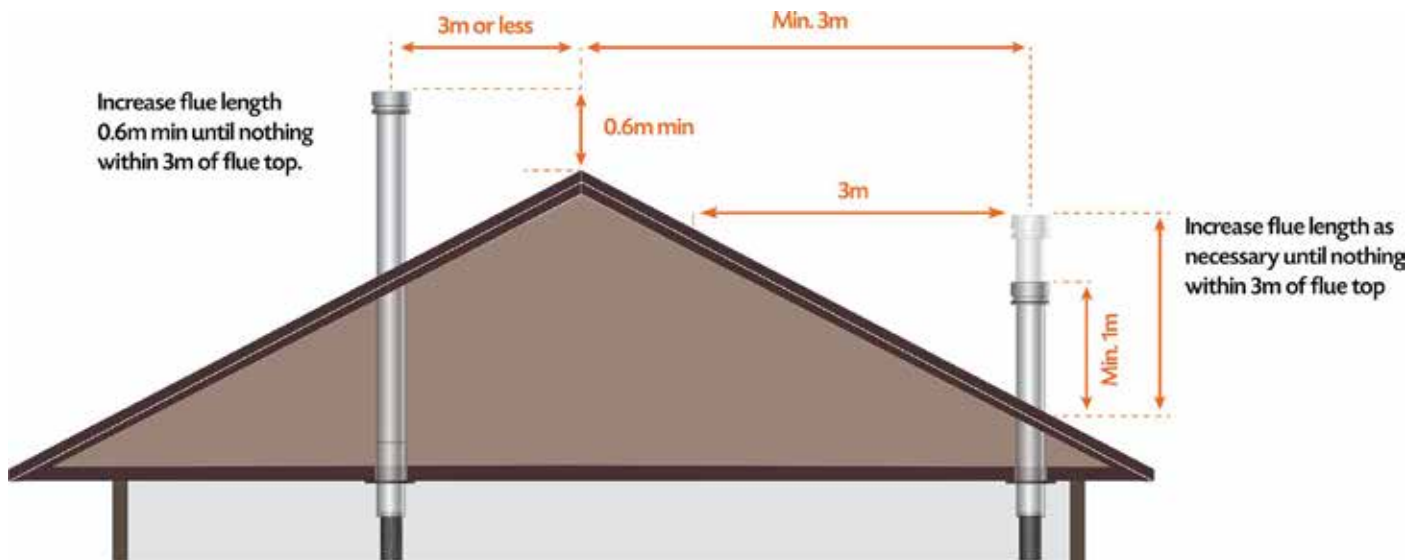

FIGURE 1

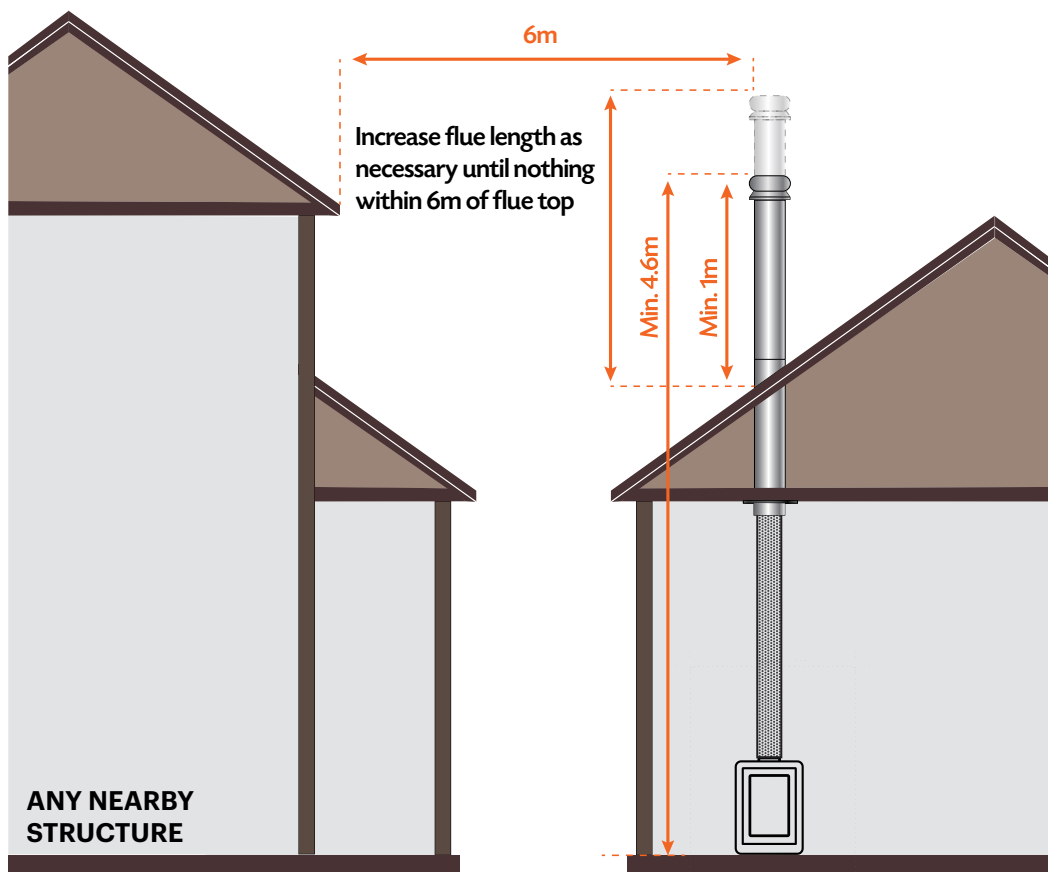
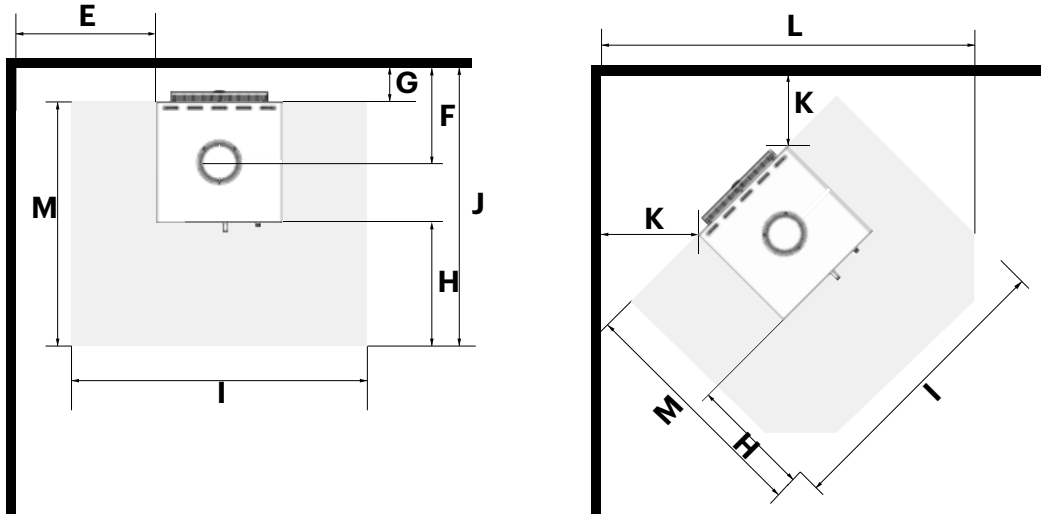

FIGURE 2

FREESTANDING INSTALLATION

CLEARANCES TO COMBUSTIBLES FOR FREESTANDING INSTALLATION

URBAN PT



URBAN LS

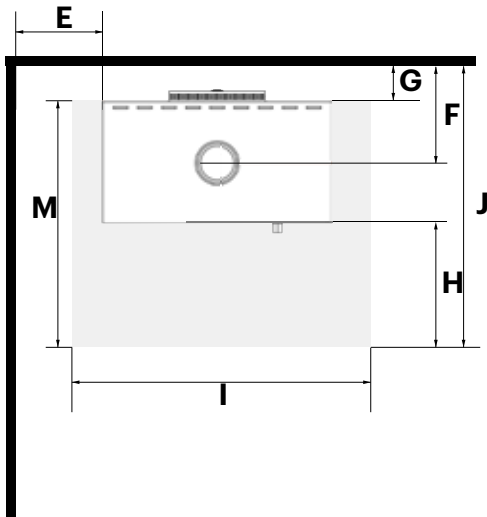

	URBAN LS		URBAN PT	
	Dec Mesh flue	Solid Flue	Dec Mesh flue	Solid Flue
E Side of the appliance to side wall or surface	550	500	500	450
F Centre of flue to rear wall or surface	555	505	402	377
G Rear of appliance to rear wall or surface	300	250	150	125
H Front of appliance to front of hearth	600	600	300	300
I Minimum hearth width	1175	1175	740	740
J Minimum hearth depth to rear wall or surface	1405	1355	955	930
K Rear corner of appliance to side wall or surface			350	350
L Minimum width of corner floor protection			1285	1285
M Minimum hearth depth	1100	1100	805	805

Manufacturers recommendation: Keep all combustible materials at least 1.22 metres (4 feet) away from the appliance. This include rugs, fabrics, furnishings, papers, firewood, etc. NEVER dry clothing on or within 1.22 metres of the appliance.

HEARTH REQUIREMENTS

FREESTANDING INSTALLATION

Urban LS: A minimum 1100mm deep x 1175mm wide x 24mm thick floor protector (compressed board) should be used under and in front of the appliance base when installing the appliance (see joint AS/NZS 2918:2018 3.3.2). The floor protector should extend 600mm in front of the appliance door and be placed centrally in the 1175mm width. The Thermal resistivity of the floor protector is 0.0782m .K/W for 24mm thick compressed board sheets.

Urban PT: A minimum 805mm deep x 740mm wide x 6mm thick floor protector (compressed board) should be used under and in front of the appliance base when installing the appliance (see joint AS/NZS 2918:2018 3.3.2). The floor protector should extend 300mm in front of the appliance door and be placed centrally in the 740mm width. The Thermal resistivity of the floor protector is 0.026m2 .K/W for 6mm thick compressed board sheets.

FREESTANDING INSTALLATION....continued

FOR CONNECTING INTO A STANDARD FREESTANDING INSTALLATION USING FORGE FLUE KITS.

The following drawing is meant as a guide only. Your wood heater must be installed by a qualified person whose work conforms with local council regulations, Australian/New Zealand standards (AS/NZS 2918:2018) & manufacturers recommendations.

Kalora wood heaters are independently tested to Australian Standards using a Forge flue kit, we always recommend using a Forge flue kit when installing a Kalora wood fire.

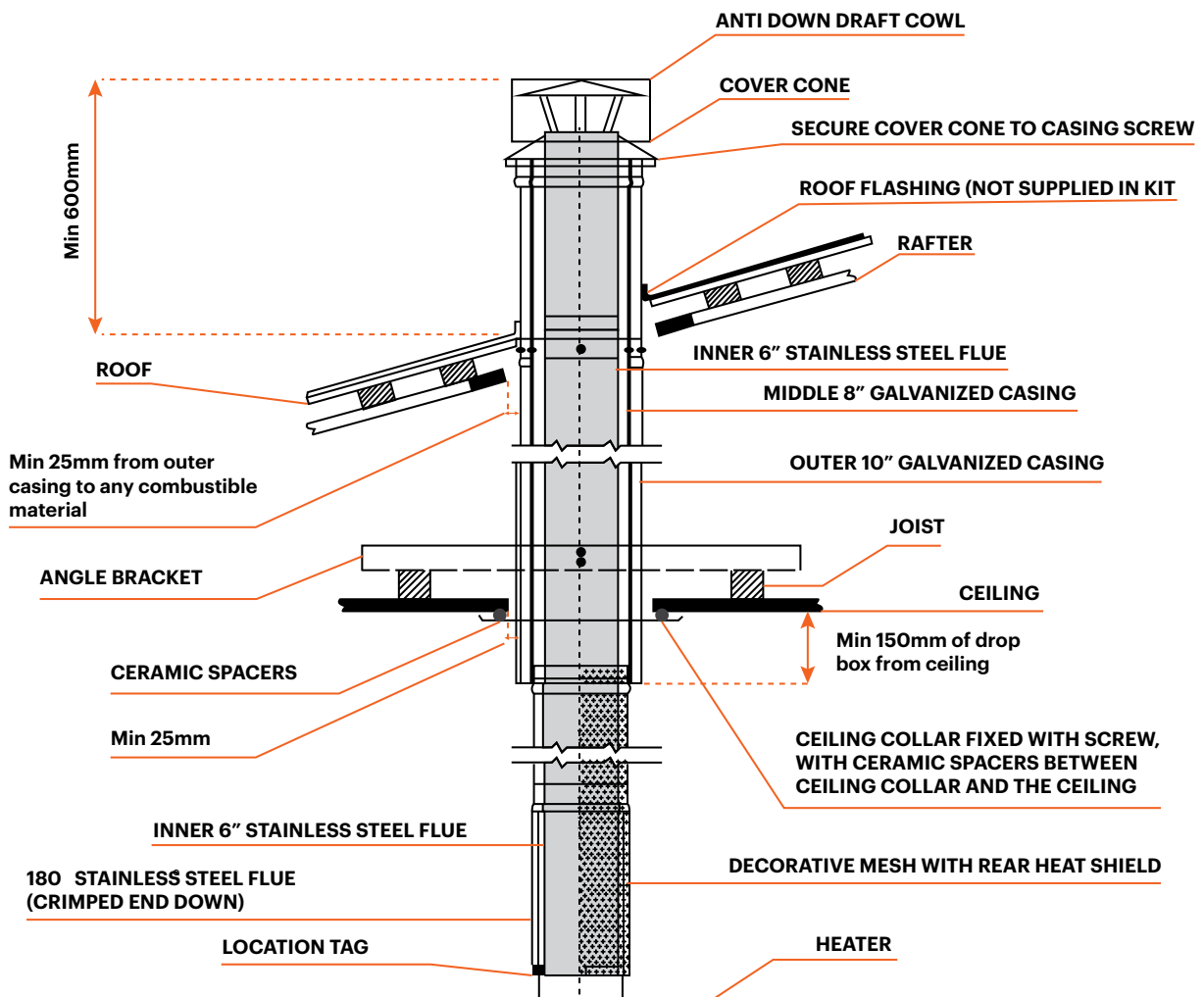

FREESTANDING INSTALLATION....continued

1. Locate wood fire in it's proposed position according to manufacturers recommendations.
2. Use a plumb bob to mark the ceiling in line with the centre of the flue collar.
3. Check that the outer casing will clear all combustible materials by 25mm. Determine positions of noggins to avoid cutting, otherwise headers must be installed for strength.
4. Cut a 305mm diameter hole in the ceiling. Directly above cut a hole in the roof to accommodate outer casing.
5. Fix the angle brackets to the joists so that the drop box (first length of located casing) is located in the centre of the hole.
6. Position the drop box between the angle brackets, keeping a 25mm clearance to combustibles. The located end of the drop box must protrude no less than 150mm down from the ceiling or any combustible material. Fix the drop box to the angle brackets.
7. Add the remaining casings to the required height. Australian/New Zealand Standards state that "the flue pipe shall extend not less than 4.6m above the top of the floor protector". If the flue pipe is within 3 metres of the ridge, the flue pipe must protrude at least 600mm above the ridge of the roof. If the distance from the ridge is more than 3 metres, the flue pipe must protrude at least 1000mm above roof penetration. Additional lengths of casing and flue may be required to achieve this. The flue pipe must be more than 6 metres from any nearby structure. Other clearances may be applicable, it is up to the installer to ensure compliance with all regulations. See Figure 1 and 2 on P7.
8. Install roof flashing (Additional accessory, not supplied in flue kit)
9. Secure the Ceiling Collar in place using ceramic spacers and screws provided.
10. Insert crimped end of the upper decorative flue (without internal stainless steel heat shield) up into the drop box. Then insert the crimped end of the lower decorative flue (with the internal stainless steel heat shield) up into bottom of the upper decorative flue. The lower decorative flue features locating tags on the non crimped end which rest on the heater flue collar.
The solid heat shield section of the decorative mesh and stainless steel inner heat shield is to face the wall.
11. Feed stainless steel flue through decorative flue and drop box through to the required height. Assemble flue pipes tight together as you go ensuring seams are straight. Secure each joint with three stainless steel rivets or screws spaced equally. Clean any finger prints or oils off stainless steel flue with methylated spirits.
12. Trim the inner flue to the same height as the outer casing. Place cover cone and cowl over stainless steel flue & push cover cone over gal casing. Fix cover cone to gal casing with stainless steel pop rivets or screws.

FREESTANDING INSTALLATION ...continued

FOR CONNECTION INTO A ROOM SEALED FLUE KIT INSTALLATION

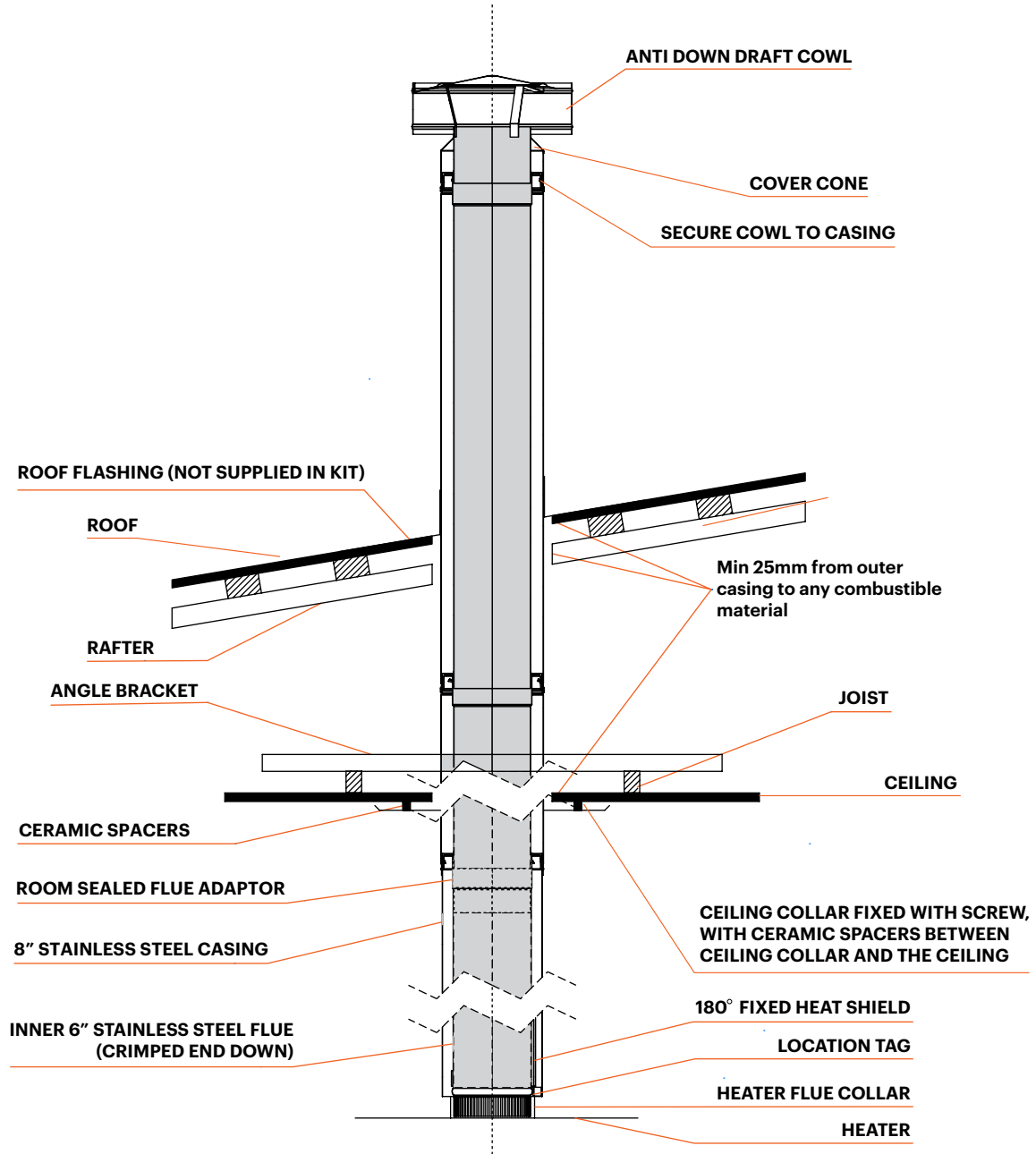

FREESTANDING INSTALLATIONcontinued

1. Locate wood fire in it's proposed position according to manufacturers recommendations.

2. Use a plumb bob to mark the ceiling in line with the centre of the flue collar.

3. Check that the outer casing will clear all combustable materials by 25mm. Determine positions of noggins to avoid cutting, otherwise headers must be installed for strength.

4. Cut a 305mm diameter hole in the ceiling. Directly above cut a hole in the roof to accommodate outer casing.

5. Fix the angle brackets to the joists so that the drop box (first length of located casing) is located in the centre of the hole.

6. Position the drop box between the angle brackets, keeping a 25mm clearance to combustibles. The located end of the drop box must protrude no less than 150mm down from the ceiling or any combustable material. Fix the drop box to the angle brackets.

7. Add the remaining casings to the required height. Australian/New Zealand Standards state that "the flue pipe shall extend not less than 4.6m above the top of the floor protector". If the flue pipe is within 3 metres of the ridge, the flue pipe must protrude at least 600mm above the ridge of the roof. If the distance from the ridge is more than 3 metres, the flue pipe must protrude at least 1000mm above roof penetration. Additional lengths of casing and flue may be required to achieve this. The flue pipe must be more than 6 metres from any nearby structure. Other clearances may be applicable, it is up to the installer to ensure compliance with all regulations. **See Figure 1 and 2 on P7.**

8. Install roof flashing (Additional accessory, not supplied in flue kit)

9. Secure the Ceiling Collar in place using ceramic spacers and screws provided.

10. Insert crimped end of the upper decorative flue (without internal stainless steel heat shield) up into the drop box. Then insert the crimped end of the lower decorative flue (with the internal stainless steel heat shield) up into bottom of the upper decorative flue. The lower decorative flue features locating tags on the non crimped end which rest on the heater flue collar. The solid heat shield section of the decorative mesh and stainless steel inner heat shield is to face the wall.

11. Feed stainless steel flue through decorative flue and drop box through to the required height. Assemble flue pipes tight together as you go ensuring seams are straight. Secure each joint with three stainless steel rivets or screws spaced equally. Clean any finger prints or oils off stainless steel flue with methylated spirits.

12. Trim the inner flue to the same height as the outer casing. Place cover cone and cowl over stainless steel flue & push cover cone over gal casing. Fix cover cone to gal casing with stainless steel pop rivets or screws.

FOR CONNECTING INTO EXISTING MASONRY CHIMNEY

Any chimney should be fully intact with no holes or missing bricks. We recommend a chimney register be installed above any installation into a masonry fireplace minimising heat loss up the chimney. The top of the chimney must be sealed using a chimney plate which should be sealed in place with a mortar mix.

Active flue should be trimmed in line with the top of the chimney if it meets the minimum height requirements under AS/NZS 2918. If additional lengths are required to fulfill this requirement these lengths must be cased.

The flue should always be finished with a cowl and cone.

PLEASE NOTE:

- There should not be any flue exposed to the elements.
- When installing your appliance in a masonry chimney, the appliance must have a minimum 10mm clearance around the unit to allow for thermal expansion.

REAR FLUE INSTALLATION

Your heater can also be installed using rear flue installation configuration. At the time this manual was printed relevant information wasn't available. Please refer to our latest manual on our website to verify the latest installation instructions and clearances to combustibles using rear flue configuration. www.kalora.com.au

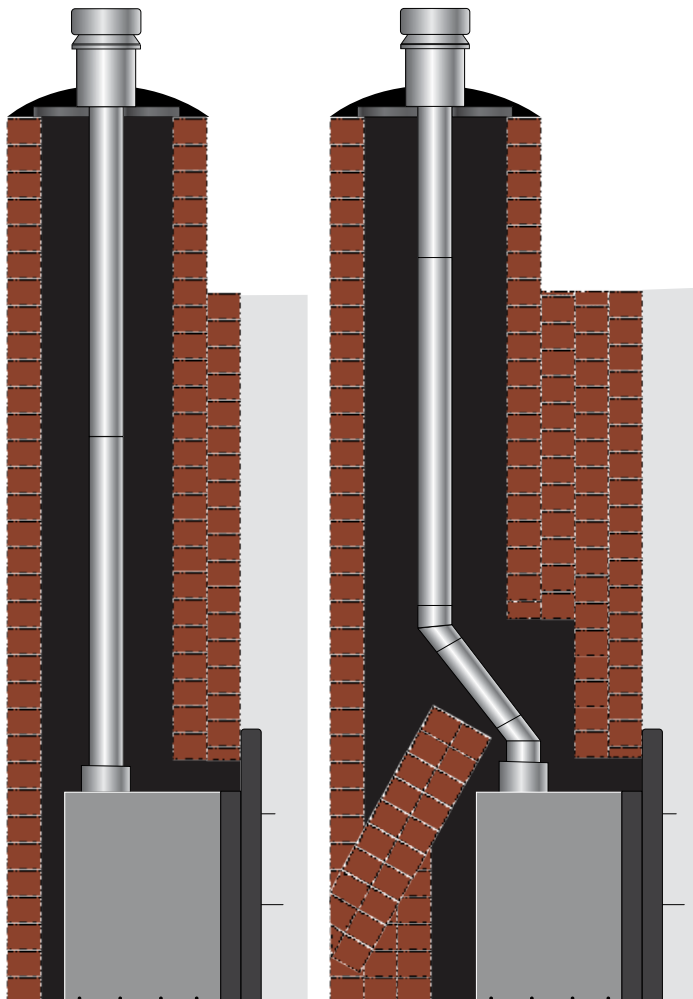

INBUILT INSTALLATION

URBAN LS THERMAL CLEARANCES

For Urban LS inbuilt installations please ensure the optional Fan accessory is **NOT** installed on the heater.

The following clearances are only applicable when installed with a Zero Clearance Box.

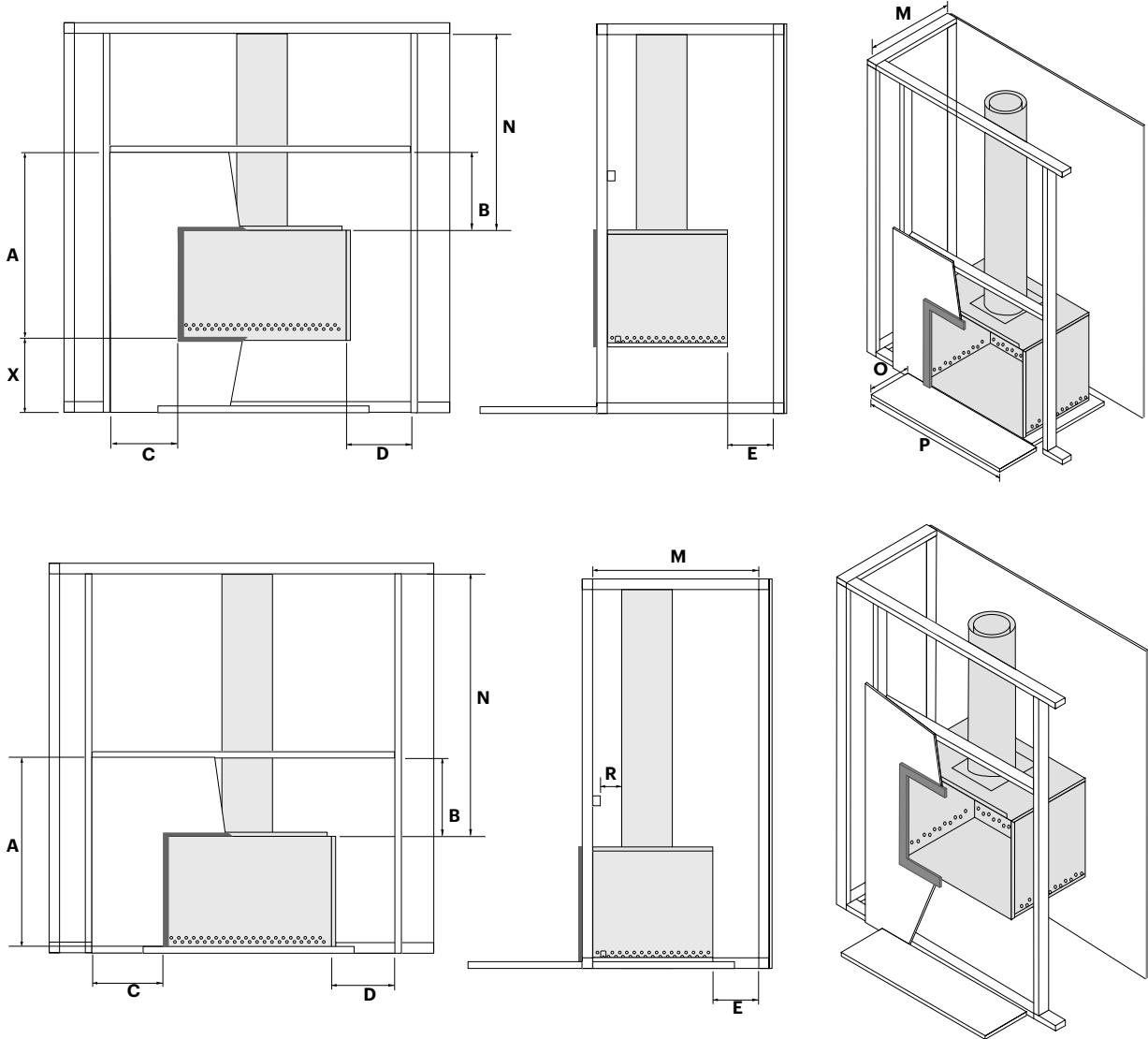

HEARTH REQUIREMENTS

URBAN LS INBUILT INSTALLATION: A minimum 630mm deep x 1130mm wide x 50mm thick floor protector should be used under the appliance, a minimum 1175mm wide x 500mm deep x 50mm thick floor protector must be used in front of the appliance base when installing the appliance.

IMPORTANT:

URBAN LS: A 50mm air gap must be maintained around the outer triple flue skin in the ceiling of the enclosure. First internal wall stud must be no closer than 125mm to the flue outer casing.

VENTILATION PORTS: To provide adequate air flow, ventilation ports should be installed into all zero clearance installations. Refer to AS/NZS 2918:2018.

INBUILT INSTALLATION....continued

URBAN LS THERMAL CLEARANCES

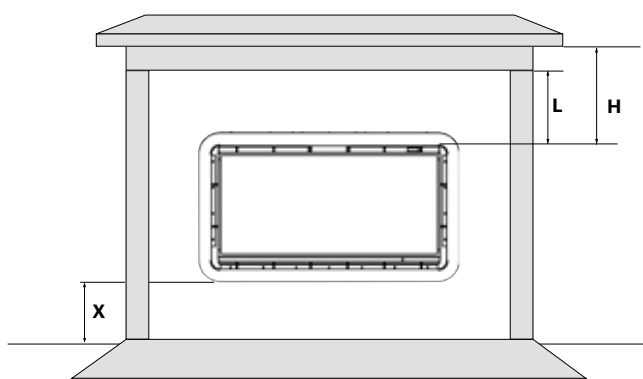
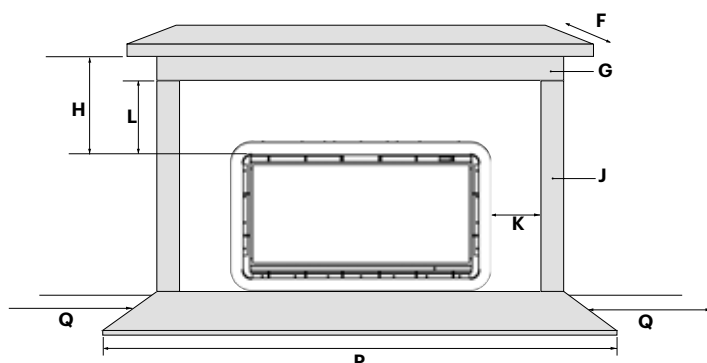

URBAN LS

A	Fire-rated board fascia minimum height from floor protector	885mm
B	Internal noggin above the appliance to the top of zero clearance box	250mm
C	Fire-rated board extension beyond the appliance	300mm
D	Side of outer casing of zero clearance box to combustibile material	25mm
E	Rear of outer casing of zero clearance box to combustibile material	100mm
F	Mantle shelf depth	430mm
G	Mantle key thickness	100mm
H	Mantle shelf to top of appliance hot air outlet	50mm
J	Mantle upright maximum thickness	45mm
K	Minimum distance to the mantel upright	50mm
L	Top of appliance hot air outlet to mantel key	385mm
M	Minimum width of combustibile enclosure	630mm
N	Timber framing in the ceiling cavity to the top of zero clearance box	> 1790mm
O	Floor protector depth	500mm
P	Floor protector width	1175mm
Q	Clearance to nearest combustibile from the side of the appliance	1200mm
R	Outer casing of flue to noggin	70mm
X	Preferred height from the floor	

INBUILT INSTALLATION....continued

URBAN PT THERMAL CLEARANCES

For Urban PT inbuilt installations please ensure the optional Fan accessory is **NOT** installed on the heater.

The following clearances are only applicable when installed with a Zero Clearance Box.

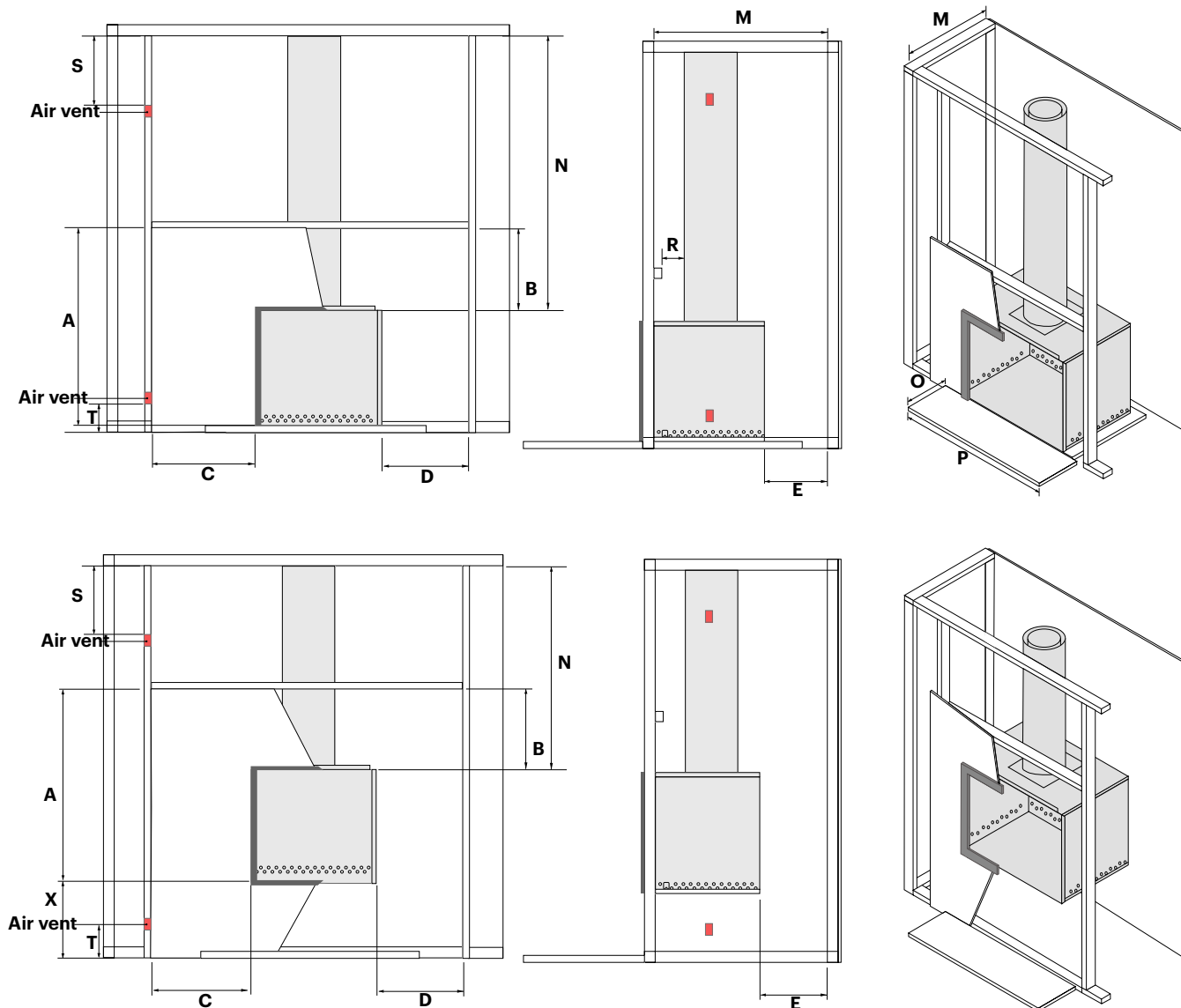

HEARTH REQUIREMENTS

URBAN PT INBUILT INSTALLATION: A minimum 625mm deep x 800mm wide x 50mm thick floor protector (Hebel blocks) should be used under the appliance base when installing the appliance and a minimum 740mm wide x 600mm deep x 50mm thick floor protector (Hebel blocks) must be used in front of the enclosure base when installing the appliance. The floor protector should extend 600mm in front of the appliance door and be placed centrally in the 740mm width. The Thermal resistivity of the floor protector is $0.33\text{m}^2\cdot\text{K}/\text{W}$ for 50mm thick Hebel Blocks.

VENTILATION PORTS: To provide adequate air flow, ventilation ports should be installed into all zero clearance installations. Refer to AS/NZS 2918:2018.

INBUILT INSTALLATION....continued

URBAN PT THERMAL CLEARANCES

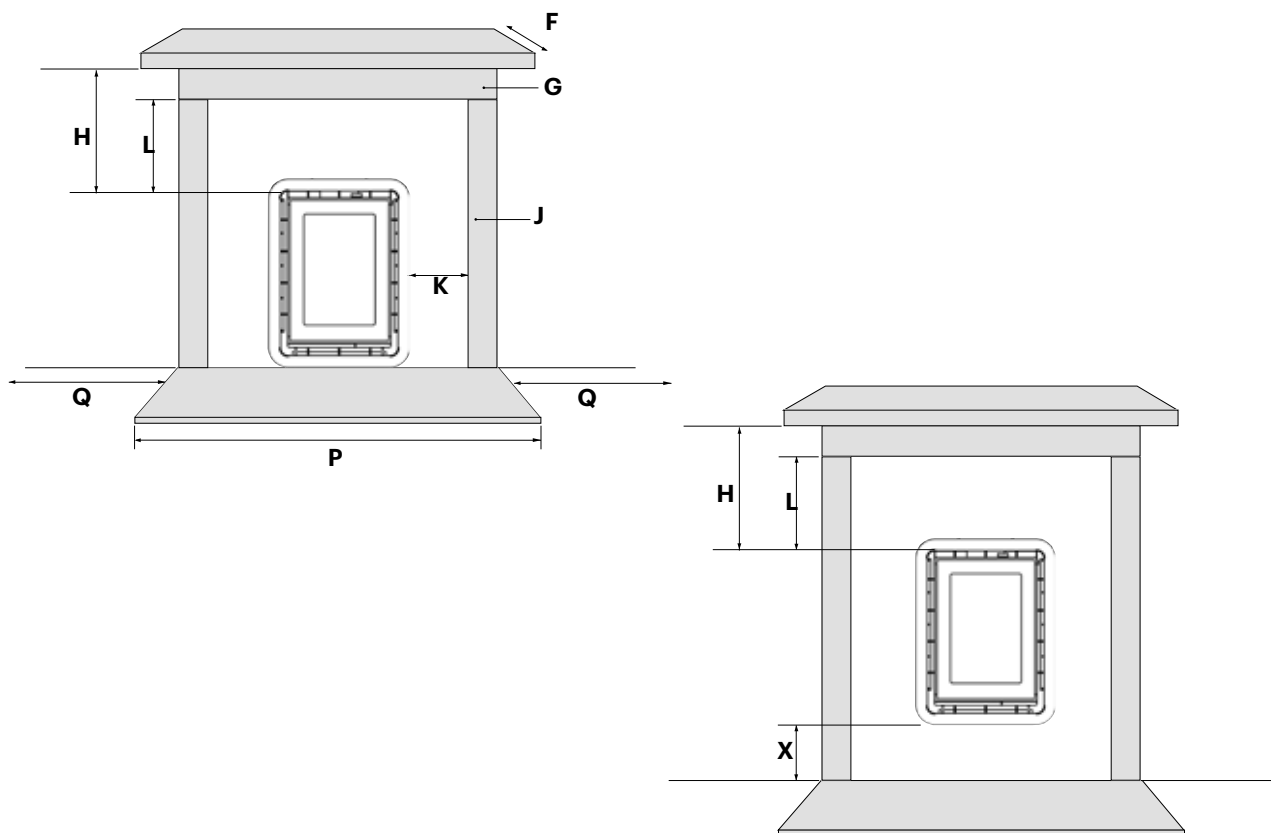

URBAN PT

A	Fire-rated board fascia minimum height from floor protector	1310mm
B	Internal noggin above the appliance to the top of zero clearance box	250mm
C	Fire-rated board extension beyond the appliance	570mm
D	Side of outer casing of zero clearance box to combustible material	25mm
E	Rear of outer casing of zero clearance box to combustible material	80mm
F	Mantle shelf depth	650mm
G	Mantle key thickness	50mm
H	Mantle shelf to top of appliance hot air outlet	50mm
J	Mantle upright maximum thickness	45mm
K	Minimum distance to the mantle upright	30mm
L	Top of appliance hot air outlet to mantel key	600mm
M	Minimum width of combustible enclosure	625mm
N	Timber framing in the ceiling cavity to the top of zero clearance box	> 1605mm
O	Floor protector depth	600mm
P	Floor protector width	740mm
Q	Clearance to nearest combustibles from the side of the appliance	1200mm
R	Outer casing of flue to noggin	85mm
S	Top of air vent to ceiling	300mm
T	Bottom of air vent to floor	50mm
X	Preferred height from the floor	

Air vents must be 50h x 200w (mm)

Fascia Installation Instructions

1. Once the zero-clearance box is installed in the desired location, position the heater inside the box.

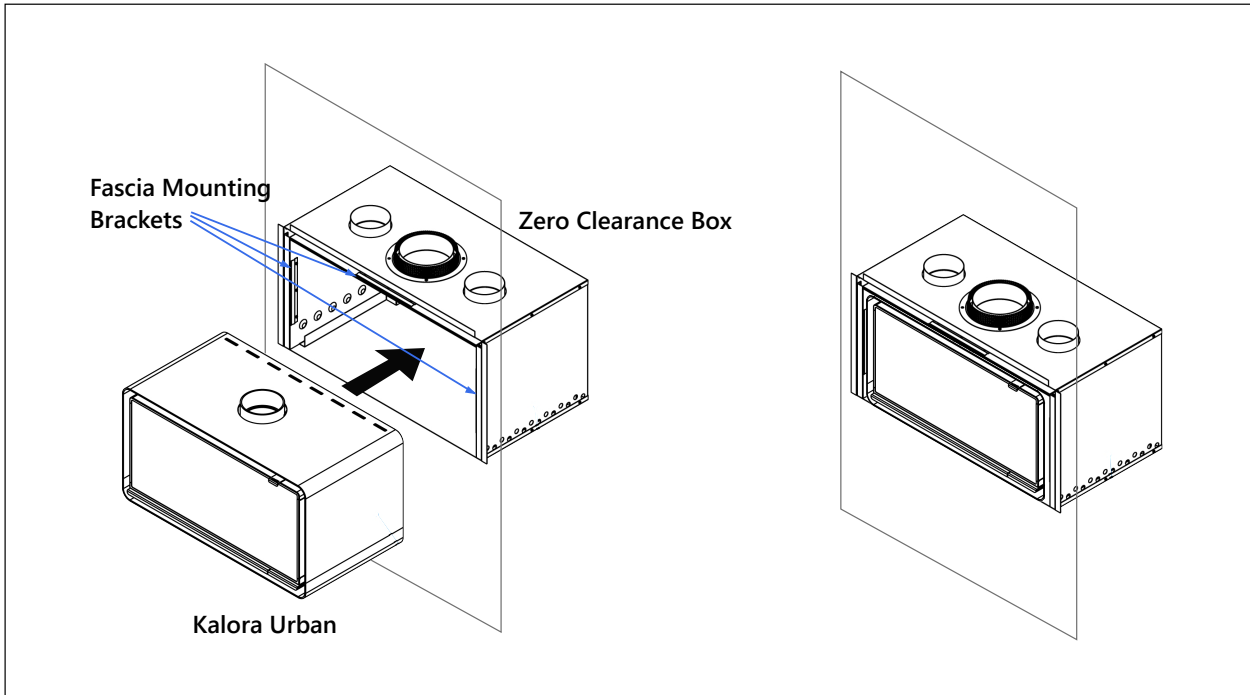

2. Align the fascia mounting plates with the corresponding mounting brackets on the inner wall of the zero-clearance box. Secure the fascia by applying firm, even pressure until the mounting brackets clamp onto the mounting plates.

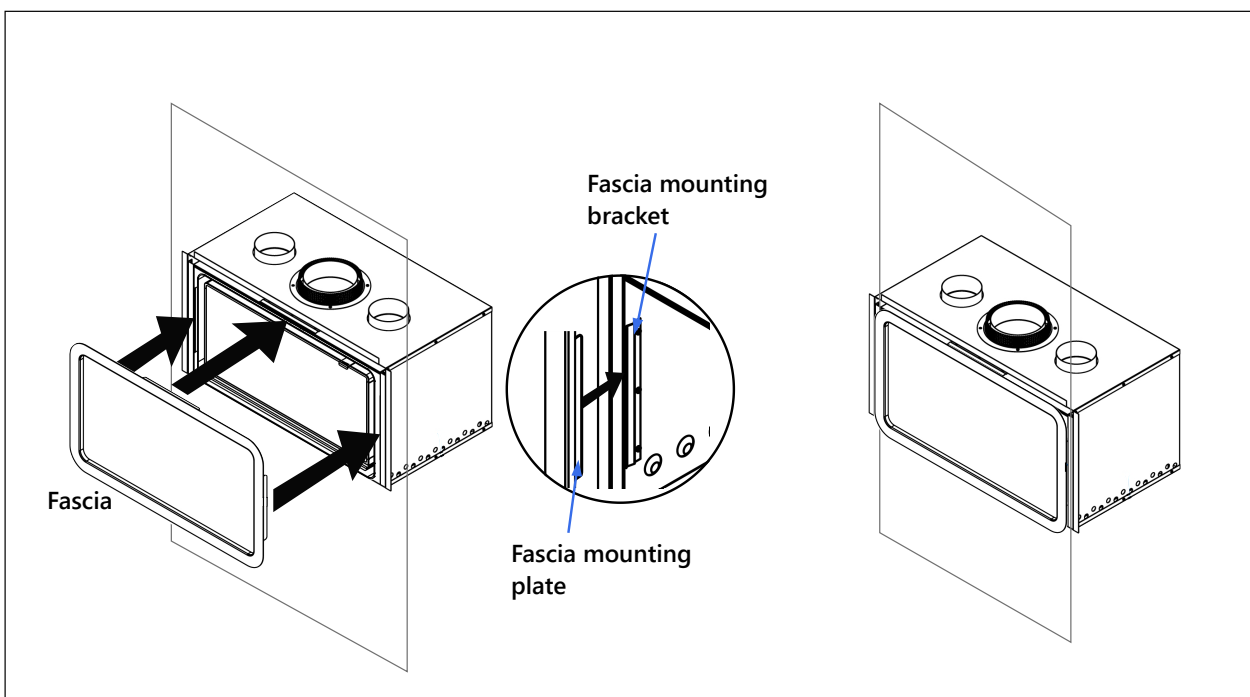

Urban LS model shown; follow the same process for an Urban PT install.

Zero Clearance Box Assembly instructions

Version 2.022/8/25

Parts

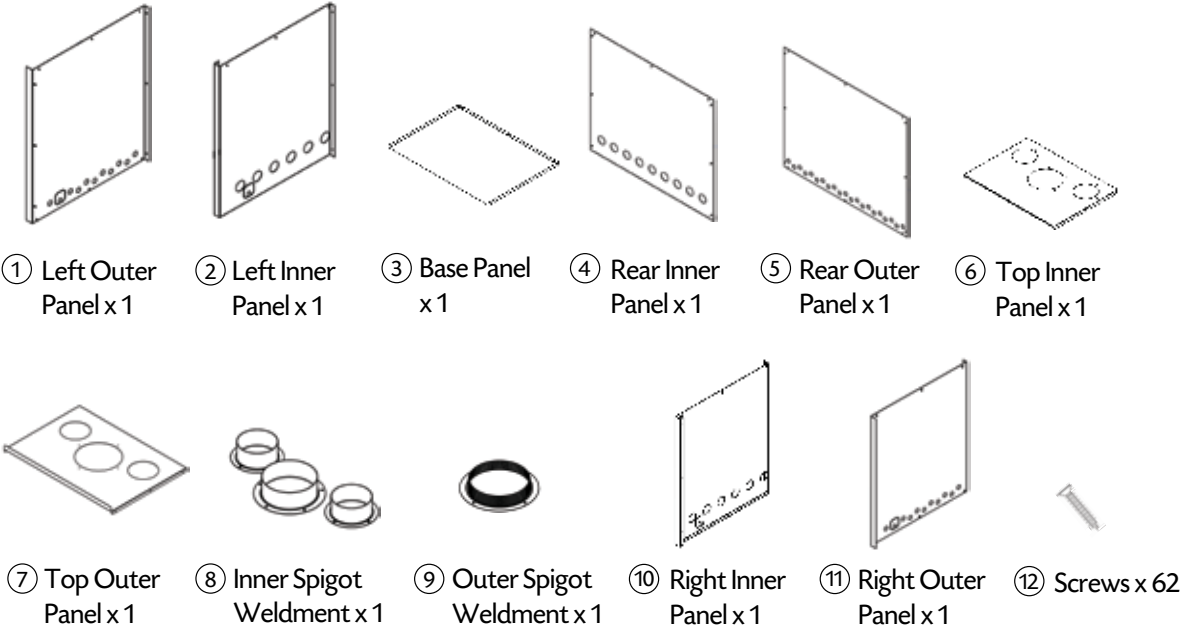

Instructions

1. Lay down the Base Panel with folded edges facing upwards and non folded edge to the front. Screw Left Inner Panel, Right Inner Panel and Rear Inner Panel together with returns facing front. Then fix the Top Inner Panel to the assembly.

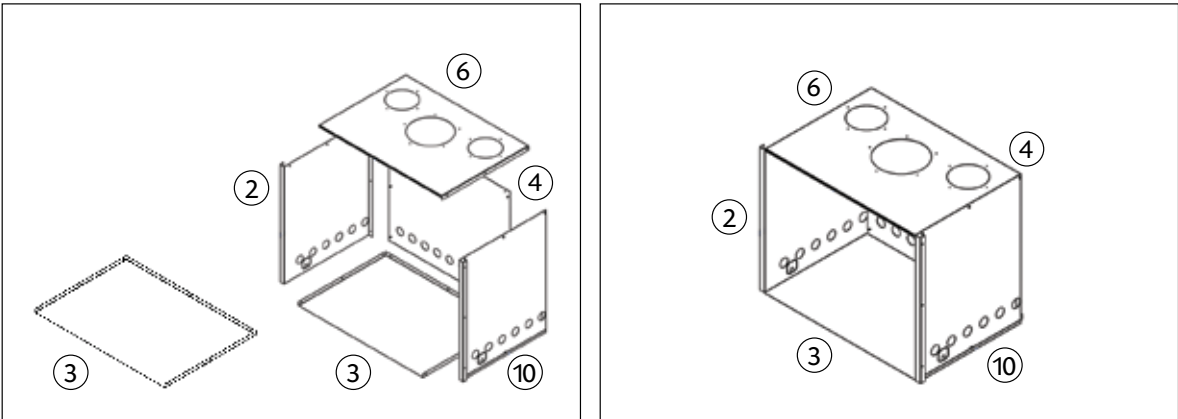

Zero Clearance Box Assembly instructions

Version 2.0 22/8/25

2. Screw in the Inner Spigot Weldments on the assembly.

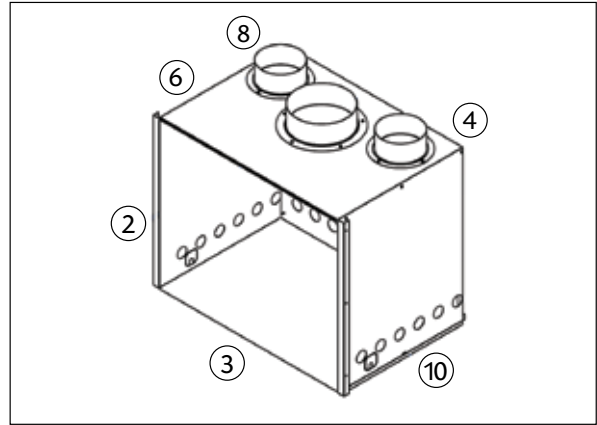
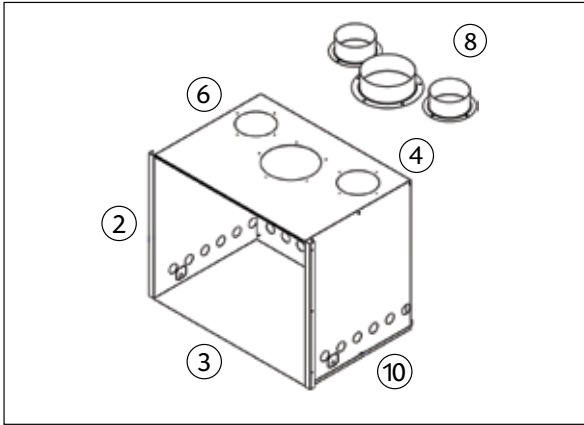

3. Attach the Left Outer Panel, Right Outer Panel and Rear Outer Panel together with returns facing front. Then fix the Top Outer Panel to the assembly with 1 large return facing upwards at front and 3 smaller returns facing downwards.

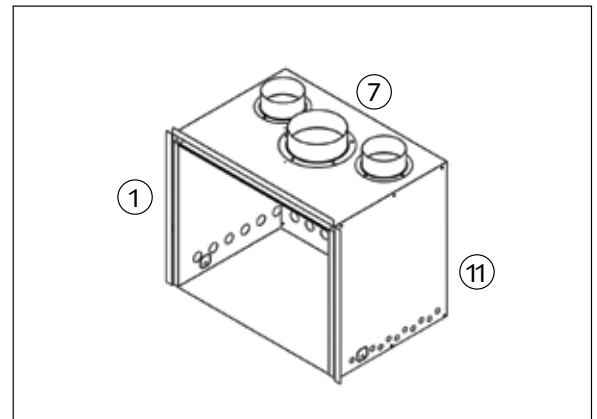
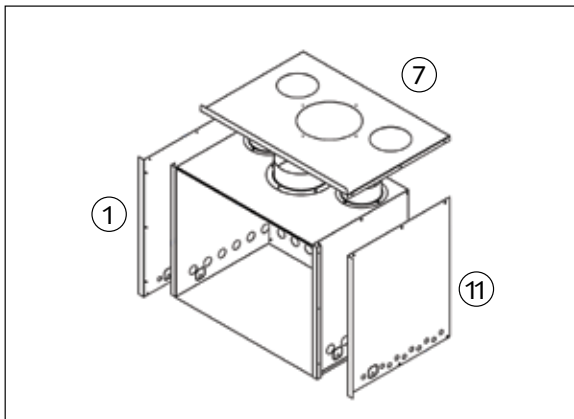

4. Screw in the Outer Spigot Weldment to complete the assembly.

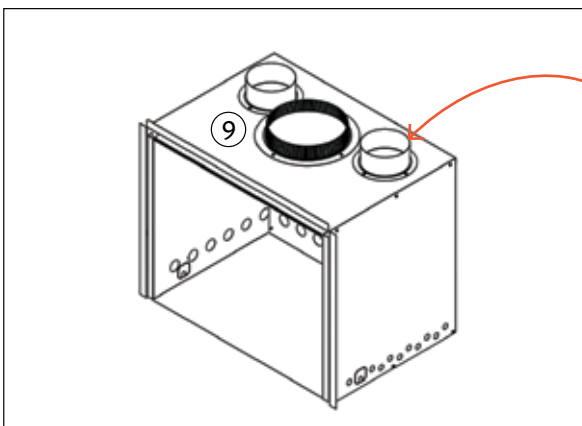

Use any of the 2 outlets to connect to the Hot Air Dilution & Distribution Kit (SG060300001) to distribute hot air from your wood fire to up to 3 additional areas.

INBUILT INSTALLATION....continued

FOR CONNECTING INTO A STANDARD INBUILT INSTALLATION USING FORGE 6" ZERO FLUE KIT.

The following drawing is meant as a guide only. Your wood heater must be installed by a qualified person whose work conforms with local council regulations, Australian/New Zealand standards (AS/NZS 2918:2018) & manufacturers recommendations.

Kalora wood heaters are independently tested to Australian Standards using a Forge flue kit, we always recommend using a Forge flue kit when installing a Kalora wood fire.

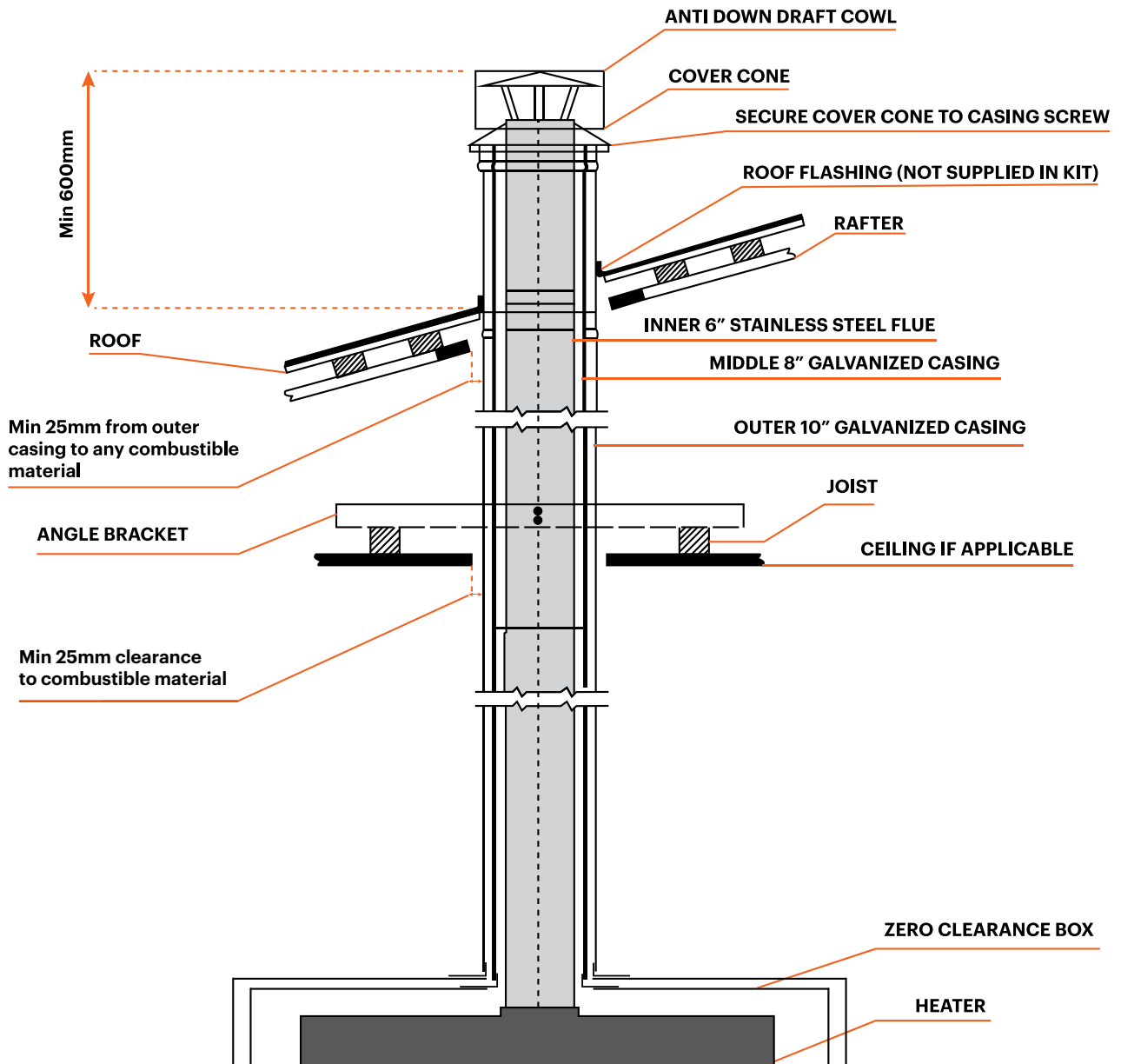

INBUILT INSTALLATION....continued

1. Locate wood fire in it's proposed position according to manufacturers recommendations.
2. Use a plumb bob to mark the ceiling in line with the centre of the flue collar.
3. Check that the outer casing will clear all combustibile materials by 25mm (Unless overwritten by the clearance instructions). Determine positions of noggins to avoid cutting, otherwise headers must be installed for strength.
4. Cut a 305mm diameter hole in the ceiling. Directly above cut a hole in the roof to accommodate outer casing.
5. Fix the angle brackets to the joists so that the drop box (first length of located casing) is located in the centre of the hole.
6. Position the drop box between the angle brackets, keeping a 25mm clearance to combustibles. The located end of the drop box must protrude no less than 150mm down from the ceiling or any combustibile material. Fix the drop box to the angle brackets.
7. Add the remaining casings to the required height. Australian/New Zealand Standards state that "the flue pipe shall extend not less than 4.6m above the top of the floor protector". If the flue pipe is within 3 metres of the ridge, the flue pipe must protrude at least 600mm above the ridge of the roof. If the distance from the ridge is more than 3 metres, the flue pipe must protrude at least 1000mm above roof penetration. Additional lengths of casing and flue may be required to achieve this. The flue pipe must be more than 6 metres from any nearby structure. Other clearances may be applicable, it is up to the installer to ensure compliance with all regulations.
8. Install roof flashing (Additional accessory, not supplied in flue kit)
9. Secure the Ceiling Collar in place using ceramic spacers and screws provided.
10. Insert crimped end of the upper decorative flue (without internal stainless steel heat shield) up into the drop box. Then insert the crimped end of the lower decorative flue (with the internal stainless steel heat shield) up into bottom of the upper decorative flue. The lower decorative flue features locating tags on the non crimped end which rest on the heater flue collar. The solid heat shield section of the decorative mesh and stainless steel inner heat shield is to face the wall.
11. Feed stainless steel flue through decorative flue and drop box through to the required height. Assemble flue pipes tight together as you go ensuring seams are straight. Secure each joint with three stainless steel rivets or screws spaced equally. Clean any finger prints or oils off stainless steel flue with methylated spirits.
12. Trim the inner flue to the same height as the outer casing. Place cover cone and cowl over stainless steel flue & push cover cone over gal casing. Fix cover cone to gal casing with stainless steel pop rivets or screws.

URBAN FREESTANDING ACCESSORIES

Both Urban LS and PT appliances have been designed to fit a range of installation options.

When fitting the following accessories please ensure clearances to combustibles are maintained and the following instructions are adhered to.

URBAN LS AND PT WOODBOX

The Woodbox has 2 locating pins to ensure the wood fire is correctly positioned, once the Woodbox is in position fix the 5 countersunk screws.

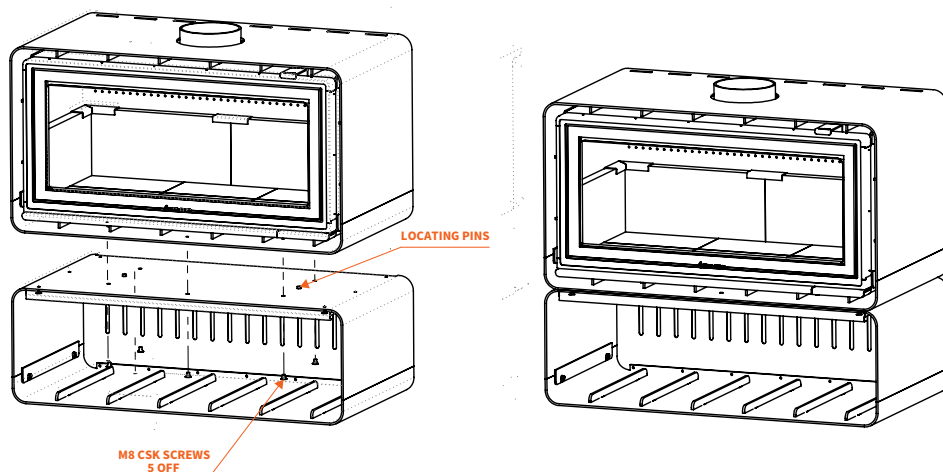

*Urban LS shown, these instructions also apply to the Urban PT

URBAN LS AND PT PEDESTAL

The Pedestal has 2 locating pins to ensure the wood fire is correctly positioned, once the Pedestal is in position fix the 4 countersunk screws.

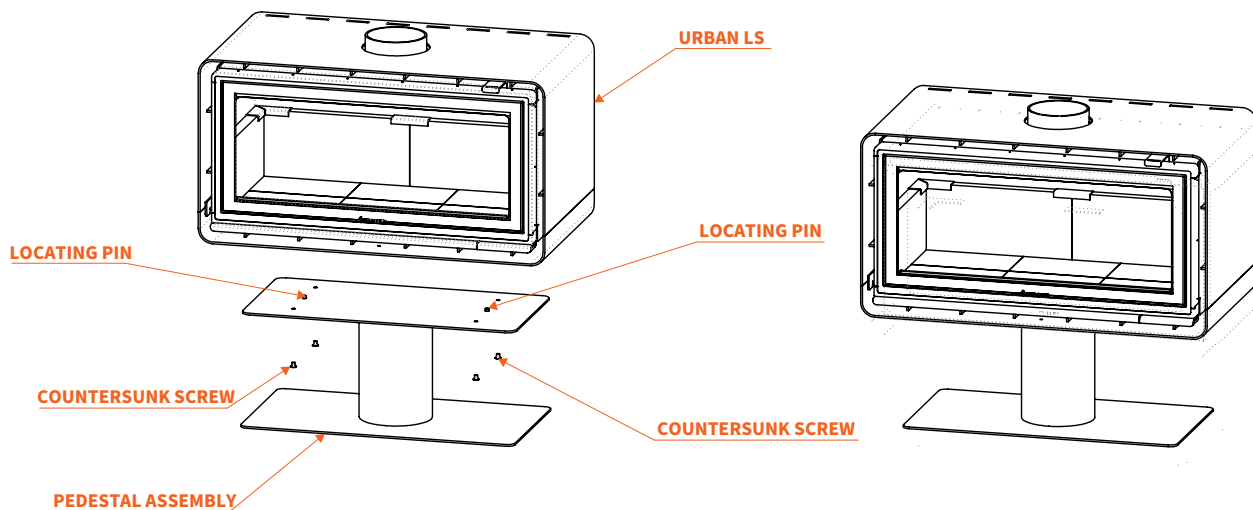

*Urban LS shown, these instructions also apply to the Urban PT

URBAN FREESTANDING ACCESSORIES....continued

URBAN LS AND PT PLINTH

There are no locating pins used for Plinth installation, position the wood fire ensuring there is no overhanging sides. Once the wood fire is in position then you can install the flue kit.

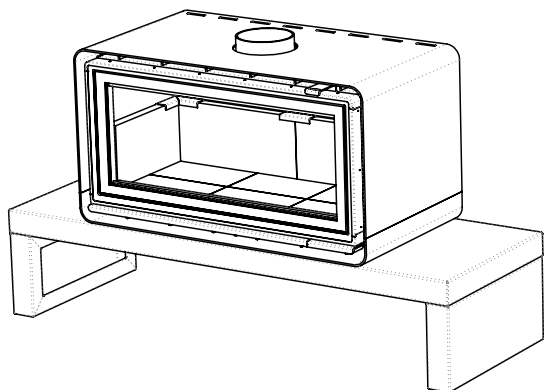

*Urban LS shown, these instructions also apply to the Urban PT

URBAN LS AND PT FREESTANDING CONVECTION FAN

Ensure there is a GPO close the wood fire. Remove the 8 fixing screws on the rear blanking plate, position the fan in place, using the same 8 screws fix the fan onto the wood fire as shown.

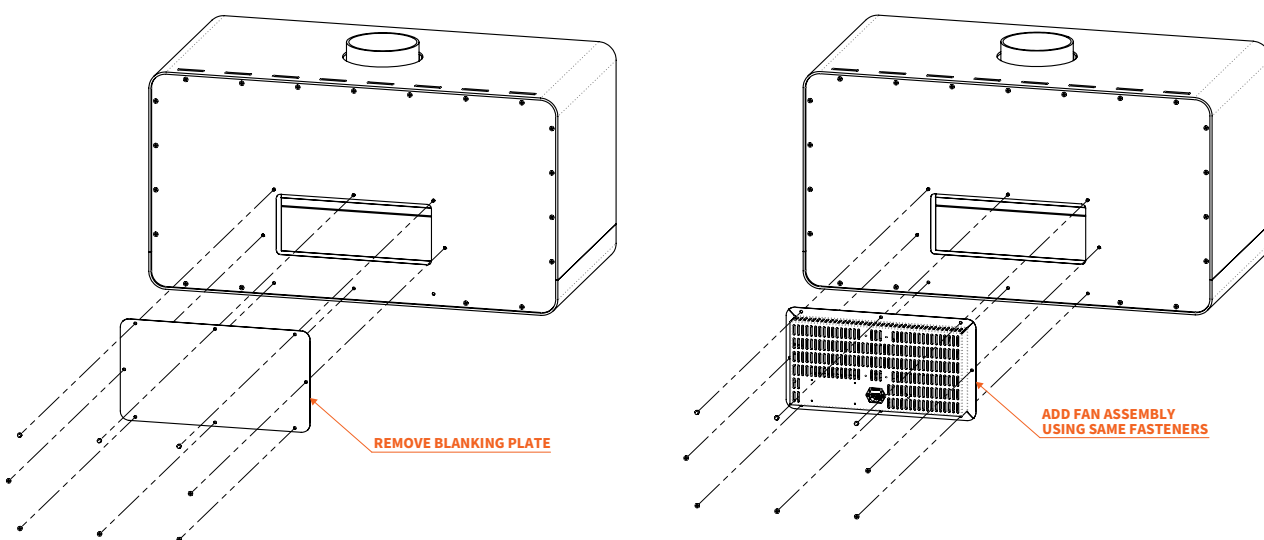

*Urban LS shown, these instructions also apply to the Urban PT

OPERATING YOUR WOOD HEATER

CONTROLS AND THEIR USE

1 Air Slide to control primary air intake
CLOSED ← → OPEN

2 Latch to open door

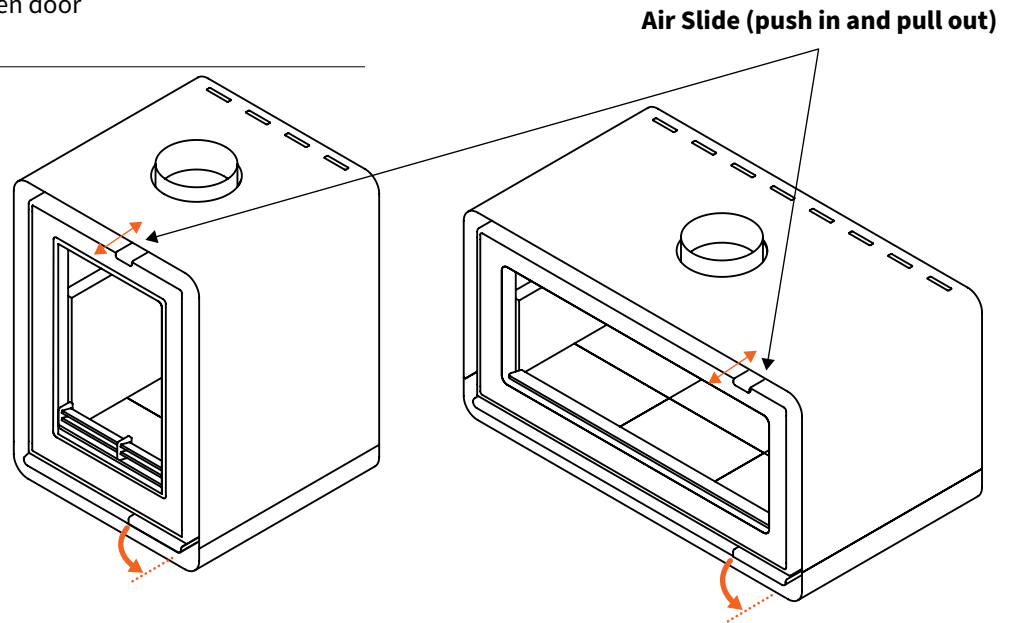

FUEL

Your wood heater is designed to burn dry hardwood only. It is NOT designed to burn the following:

- Soft wood
- Treated or painted wood
- Paper or cardboard, other than small amounts used to light stove.
- Plastics
- Synthetic fuel or logs that are not approved for solid fuel stoves
- Household rubbish
- Liquid fuels

Burning these or other products for which the wood heater was not designed may damage the wood heater and cause a fire hazard or release toxic fumes.

Fuel should be stored in a dry place; wood should be dried for at least 1 year and have a moisture content of less than 20%. Wet wood may cause serious creosote build up, which may damage your flue system and even your wood heater. Therefore the use of green, sappy or wet wood is strongly discouraged.



CAUTION! IMPORTANT INFORMATION FIRST OPERATION OF STOVE

When operating, this unit will get extremely hot. Do Not Touch, use tools where necessary. You should begin using your wood heater by lighting small fires which get progressively larger. We recommend lighting approximately 5 small fires before you put the wood heater into full service. Allow the wood heater to fully cool between each of these fires. There may be some smell and a small amount of smoke from the wood heater during the initial operations. This is perfectly normal and is merely the curing of the wood heater paint. Opening a window or door to provide additional ventilation will help alleviate this.

OPERATING YOUR WOOD HEATERcontinued

AIR CONTROLS

Your wood heater needs air to burn the fuel. Kalora wood heaters draw air from multiple areas to maximize efficiency. The air is supplied through an adjustable primary air slide at the front right side of the wood heater and secondary non-adjustable air through the rear of the firebox and air-tube.

Primary air, as the name suggests, is used for the initial burning of the fuel and is also used to keep the stove glass clean. Secondary air is used for secondary combustion, which makes the stove more efficient and reduces emissions.

The settings of the primary air control very much depends on draught and local conditions and after a few fires, you should have a good idea of the best settings for your wood heater. The air slide control should be fully opened when lighting the fire. Once the fire is established, the air slide control may be adjusted as required. Reducing the air intake will cause the wood heater to burn slower. This may cause some blackening of the stove glass, but this should burn off once the wood heater is burning brightly again.

LIGHTING THE FIRE

1. Ensure the air slide is in the open position or high position
2. Place firelighters approx. 10 – 15cm apart depending on firebox size. Don't use newspaper as it burns too quickly and creates excessive emissions
3. Now place softwood kindling in a criss-cross pattern on top of the firelighters. Soft wood kindling is best because the fire will light quicker and burn hotter.
4. Light the fire using either match or gas lighter. Once kindling is ablaze you can close the door; however, do not latch the door, this will allow extra air into the firebox and gets the fire going quicker and cleaner. Leave the door like this for 5-10 minutes. Never leave an unlatched firebox door unattended, it could be a fire risk.
5. After 5-10 minutes, it's time to add pieces of hardwood to the firebox. The pieces of hard wood should be no wider than a drink can. Again, load the wood in a criss-cross pattern, ensuring the flame gets enough air.
6. Latch the door so it's completely closed for 30 minutes.
7. Expert tip: if your heater has a fan, do not turn it on for at least 45 minutes otherwise you'll just blow cold air over a cold firebox making your fire burn inefficiently and it can also blow cold air throughout the home.
8. After 30 minutes has passed its time to put the large pieces of hard wood on the fire. This wood should be no bigger than a loaf of bread. Close and latch the door after loading.
9. After 45 minutes your firebox will be fully ablaze and will be producing a consistent strong amount of heat. You can now lower the airside to slow the fire down and create the comfort level you require. If you have a fan fitted you can now turn it on.

REFUELING

Before refueling your wood heater, turn the air supply to high for a few moments until there is a good fire in the heater. This will ensure there is no build-up of harmful gases in the wood heater when the door is opened and will also get the new fuel burning quickly and not allow it to kill the fire. Open the door slowly in case any logs or coal have fallen against the glass. Opening the door quickly may result in smoke being drawn into the room.

To reload the wood heater, open the door and feed the fuel in slowly always using either tongs, a small shovel along with protective gloves. Do not overfill the wood heater. It is always better to put in small loads often rather than big fills less frequently. Wood should be loaded in a front to back direction, this helps air flow as well as reducing the risk of logs falling forward. Close the door gently after wood heater is reloaded.

OVERNIGHT BURNING

Your wood heater is designed to maximise burn times. Best results are achieved when you establish a good fuel bed in the wood heater and allow it to burn for about 30 minutes before closing the air slide control fully.

When you return to your wood heater, fully open the air slide control until you have a good fire and then set to normal operating levels. Do not add fuel until the fire bed is hot and red. Then add a little for the first time and allow that to ignite before adding more. During overnight burning, the wood heater glass may blacken, but when a hot fire is established again this should burn off.

WOOD HEATER MAINTENANCE

CHECK YOUR WOOD HEATER REGULARLY

Initially, we recommend you check your flue system at least once per month. After the first few months you will notice a pattern of soot and creosote build up and you can then determine an inspection interval for checking soot and creosote build up that is suitable for your wood heater installation.

Other checks, as listed below, should be carried out at least twice per year. If you notice anything wrong at any time it should be repaired immediately. Never use a wood heater that is in any way damaged or has a damaged flue.

1. Check your flue system for build up of soot or creosote and for signs of damage to joints.
2. To check flue outlet remove top of baffle by lifting and pulling out at end. Use a flashlight to check flue outlet.
Clean and repair as necessary. Always replace top baffle before relighting stove.
3. Check that glass is not cracked or chipped and that the sealing rope is in good condition. Replace as necessary.
4. When the room is dark, use a strong flashlight to check the sealing of the wood heater at the edge and corners for leaks. Any leaks or cracks found should be repaired with fire cement or damaged parts should be replaced with genuine spare parts.
5. During periods in inactivity or infrequent use, regularly alternate the position of the flue damper. We also recommend placing a silica bag in the firebox to absorb any moisture which may cause rust.
6. Check that wood heater door is tight and well sealed when closed. Place a strip of paper into the wood heater and close the door, try to pull out paper. You should feel some resistance to your pull, check several points around the door. If it pulls out too easily, replace the rope and seal in place with a suitable high temperature sealant.
7. Check baffle plate and firebricks. Baffle plate should be replaced if a hole appears in the surface of the plate. Firebricks should be replaced when they start to crumble or the firebox is exposed.

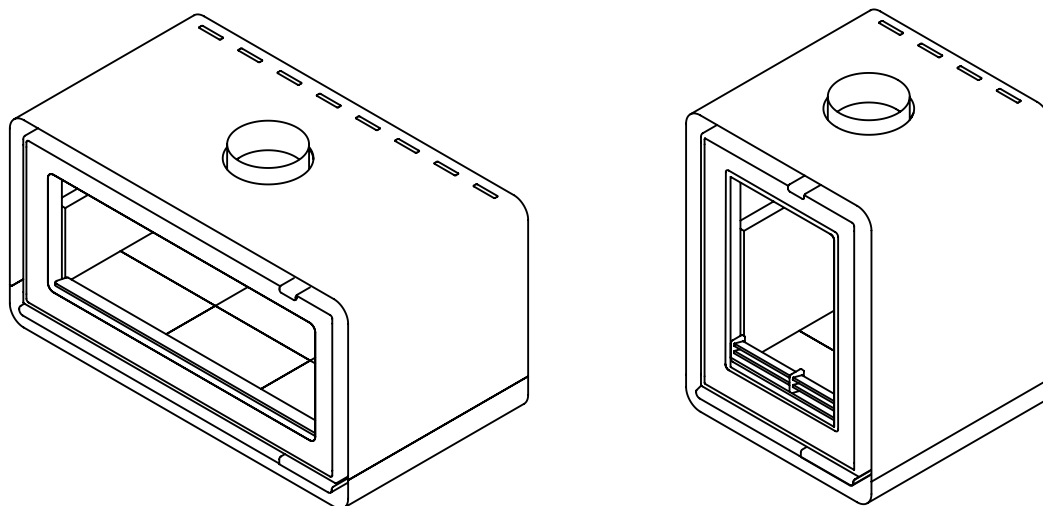

WOOD HEATER MAINTENANCEcontinued

ASH REMOVAL

When the stove is out and completely cold you may remove the ash using an ash vacuum or a steel bucket with a lid and shovel. Place a cover over the bucket so that when removing the bucket the ash does not blow about your house.

CARE OF GLASS

At times, especially when the air controls are turned to low settings or when damp wood is used, the wood heater glass will blacken. This is caused by fuel that is not completely burnt, but the build-up on the inside of the glass will normally burn off when a good hot fire is established in the wood heater.

There may be times however when you need to clean the glass. To do this, use a soft cloth and a non-abrasive glass cleaner.

Only ever clean the glass when the wood heater is cold. For best results select from Kalora's range of glass cleaning products. When loading fuel into the wood heater, always make sure it is not protruding out through the door opening, as this may break the glass when you close the door. This is especially relevant when loading logs. Always close the door gently.

If the glass does crack when the wood heater is lit, let the fire die out. Do not open the door until the wood heater has fully cooled. Replace the glass with the specified replacement part before re-using the wood heater.

REPLACING PARTS

Always use genuine replacement parts. Only ever make replacements when the wood heater is cold.

All replacement parts can be ordered from www.kalora.com.au.

SURFACE FINISH

To clean your heater wipe lightly with a damp cloth or dust with a duster. Some cleaning products may leave stains on the wood heater surface. Never use abrasive cloths as these may scratch the surface; take caution when using microfiber cloths as they can leave swirl marks if used in a circular motion. Painted wood heaters can be re-painted by using a good quality, high temperature wood heater paint. When re-painting, make sure there is plenty of ventilation and follow the manufacturer's instructions. Allow the paint to fully dry before lighting the stove and allow extra ventilation for the first couple of fires as some fumes may emit from the stove as the paint cures.

Kalora high temp enamel is available at your local Kalora retailer.

Visit www.kalora.com.au for details.

TROUBLESHOOTING

Many people under estimate the importance of using a professional installer with experience in wood heating who adheres to Australian Standards to install their wood fire.

If you are having issues with your wood fire not working the way you think it should, we implore you to speak to your installer first; they can help you with issues such as burning too much or too little wood, smoke in the room when you open the door, blackened glass or build-up of creosote during use. A professional installer can also provide guidance on whether the problem is a manufacturing issue; in this instance we will work with the contractor to resolve any issues as soon as possible for you.

It is important to remember that all flue installations must be compliant with Australian Standards. A heater installed with a non-compliant flue configuration will not perform as advertised or as tested.

FIRE NOT BURNING

A wood heater not burning is generally caused by either a shortage of air and/or incorrect or damp fuel.

If fuel is not the problem check:

-
1. That the air controls are opened.

 2. There is no blockage in the flue system.

 3. That the open end of the flue is above the height of any nearby obstructions.

 4. That there is a sufficient air supply into the room and that this supply is not being taken by an extractor fan.

GLASS BLACKENS

Glass usually blackens when:

-
1. The fuel is not being burned efficiently because of starvation of air.

 2. Bad quality or damp fuel is being used.

Please note: For optimum efficiency always use a good quality dry hardwood.

FIRE BURNING TOO QUICKLY

This is usually caused by too much draught or air.

-
1. Firstly try reducing the air supply to the wood heater by closing down your air controls, if this fails then you may have to adjust the door or you may have damage to the sealing.

 2. Close a thin strip of paper in the door, check to see if the paper stays in place or pulls out. If the paper pulls out easily you may need to adjust or replace the door seal.

 3. Check to see if the glass moves within the door frame. If it does you may need to tighten the glass retainer screws.

 4. Check the condition of the door sealing rope and the glass seal tape.

TROUBLESHOOTINGcontinued

SMOKE IN ROOM

If the wood heater is properly installed it should not emit any smoke into your room. Should this happen, check that your room is not air tight. This can easily be checked by opening a door or window. If the smoking stops you need to provide an additional air supply into the room. If this is not the problem, check if your chimney is blocked or obstructed and that you are not getting a down draught caused by the location of the open end of the flue pipe or chimney.

If the problem persists contact your installation company and ask them to get your chimney and stove installation checked.

CHIMNEY FIRE

Chimney fires occur when soot and creosote that have built up in the flue system ignite. If the wood heater is operated properly and the flue checked and cleaned regularly then chimney fires should not occur. These fires can be very dangerous and must be avoided. Try to maintain good, hot fires in the wood heater whenever possible and at least once in every firing open the air controls and allow the wood heater to burn on full for a short while until the entire fire bed is glowing red.

Check your flue system regularly for build-up of soot and creosote and clean as necessary. Chimney fires can be detected by sparks coming from the top of the chimney, a roaring sound coming from the area of the stove or chimney or vibration in the stove or chimney. In the event of a chimney fire, close the air controls, evacuate the building and call the fire department. Do not relight the stove after a chimney fire until the stove and flue have been checked and any necessary repairs have been carried out.

WARRANTY

KALORA LIMITED WARRANTY

This limited warranty is given by Kalora Pty Ltd (ACN 005 868 093) (Kalora or we) to the original retail purchaser (you) of the wood heater to which this Warranty applies.

Our goods come with guarantees that cannot be excluded under the Australian Consumer Law. You are entitled to a replacement or refund for a major failure and for compensation for any other reasonably foreseeable loss or damage. You are also entitled to have the goods repaired or replaced if the goods fail to be of acceptable quality and the failure does not amount to a major failure.

The benefits that this Warranty provides are in addition to other rights and remedies available to you under the Australian Consumer Law. This Warranty does not limit those rights and remedies.

SCOPE OF WARRANTY

If a defect in material or workmanship appears in the following parts within the corresponding warranty period after the date of the original purchase, such as to make the wood heater unfit for normal home use; and you comply with the requirements below regarding making a claim, then, subject to the exclusions below, we will replace or repair the relevant part or (at our option) replace the entire wood heater with the same or comparable model.

PART	WARRANTY PERIOD
Firebox	15 Years
All other parts (Including fans, other electrical items, top baffles, firebrick retainers)	1 Year

To the extent permitted by law, our liability under this Warranty is limited to this replacement or repair obligation.



CAUTION! IMPORTANT INFORMATION

For this Warranty to apply, you must fully complete the Warranty Registration Form and mail it to our mail address (below) within 30 days after the original purchase. By completing this form, you also agree that, to the extent permitted by law, our liability to you on any basis in relation to the wood heater (other than under the Australian Consumer Law) is limited to our obligations under this Warranty.

WARRANTYcontinued

EXCLUSIONS

This Warranty does not apply:

-
1. Where the defect is not due to the original design or manufacture of the part (including where the wood heater, part or accessory has been subject to accident, abuse, alteration, misuse or neglect or has been installed, inspected, operated or maintained negligently or not in accordance with applicable local laws and regulations and the manufacturer's printed instructions, if any)

 2. Where the firebricks, top baffle or fibreglass seal have not been replaced after becoming damaged or worn

 3. To any accessories or optional parts

 4. To any glass, paint, firebrick, fibreglass seal sold or used with the wood heater

 5. To any surface rust which may occur in transit, storage or use.
This includes installations in close proximity to coastal areas and salt water which may cause rust to the appliance.

HOW TO MAKE A CLAIM

Any claim under this Warranty must be in writing to our mail address below. It must be sent within the applicable warranty period and must state:

-
1. The model and serial number of the wood heater

 2. The place, price and date of purchase

 3. Reasonable details of the defect

To obtain replacement or repair under this Warranty, the wood heater must be returned to the original place of purchase (and collected from there once the replacement or repair is complete) at your cost. Kalora will not be responsible for any associated freight, disconnection or re-installation costs (including labour costs). Kalora will only be responsible for transport of the wood heater from the original place of purchase to Kalora's premises (and back), and replacement or repair in accordance with this Warranty.

REGISTER YOUR PRODUCT



REGISTER BY MAIL

Alternatively, please complete the attached warranty card within 30 days of installation and return to:

Kalora Pty Ltd.
58 Access Way, Carrum Downs
Victoria, Australia, 3201

URBAN LS SPARE PARTS

SPARE PARTS

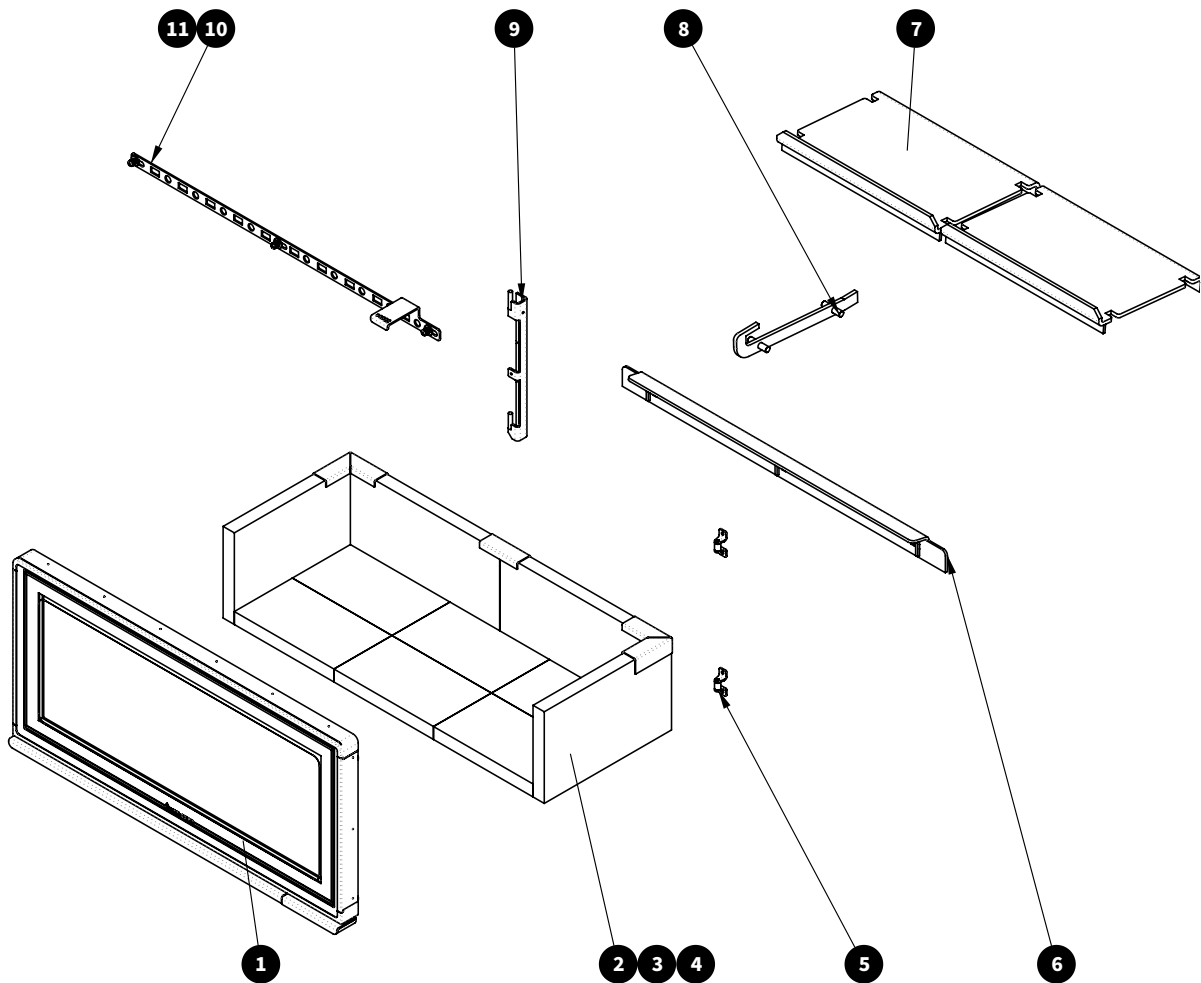

LEGEND	PART	QTY	KALORA PART NO.
1	Kalora Urban LS Door Assy	1	SG031000168
2	Set Firebrick Vermiculite Landscape	1	SG030600041
3	Brick Retainer Rear	1	SPSTY112
4	Brick Retainer Corner	2	SPSTY111
5	Door Latch on Body Black	2	SPMR512B
6	Kalora Urban LS Ash Lip	1	SG030700496
7	KA Urban Baffle Plate	2	SG030700911
8	KA Urban LS Centre Baffle Support	1	SG030700503
9	KA Urban Door Hinge	1	SG030700500
10	Kalora Urban Landscape Airslide St/St	1	SG030700640
11	Kit Fasteners Air Slide	3	SG031300118

URBAN LS SPARE PARTScontinued

DOOR ASSEMBLY SPARE PARTS

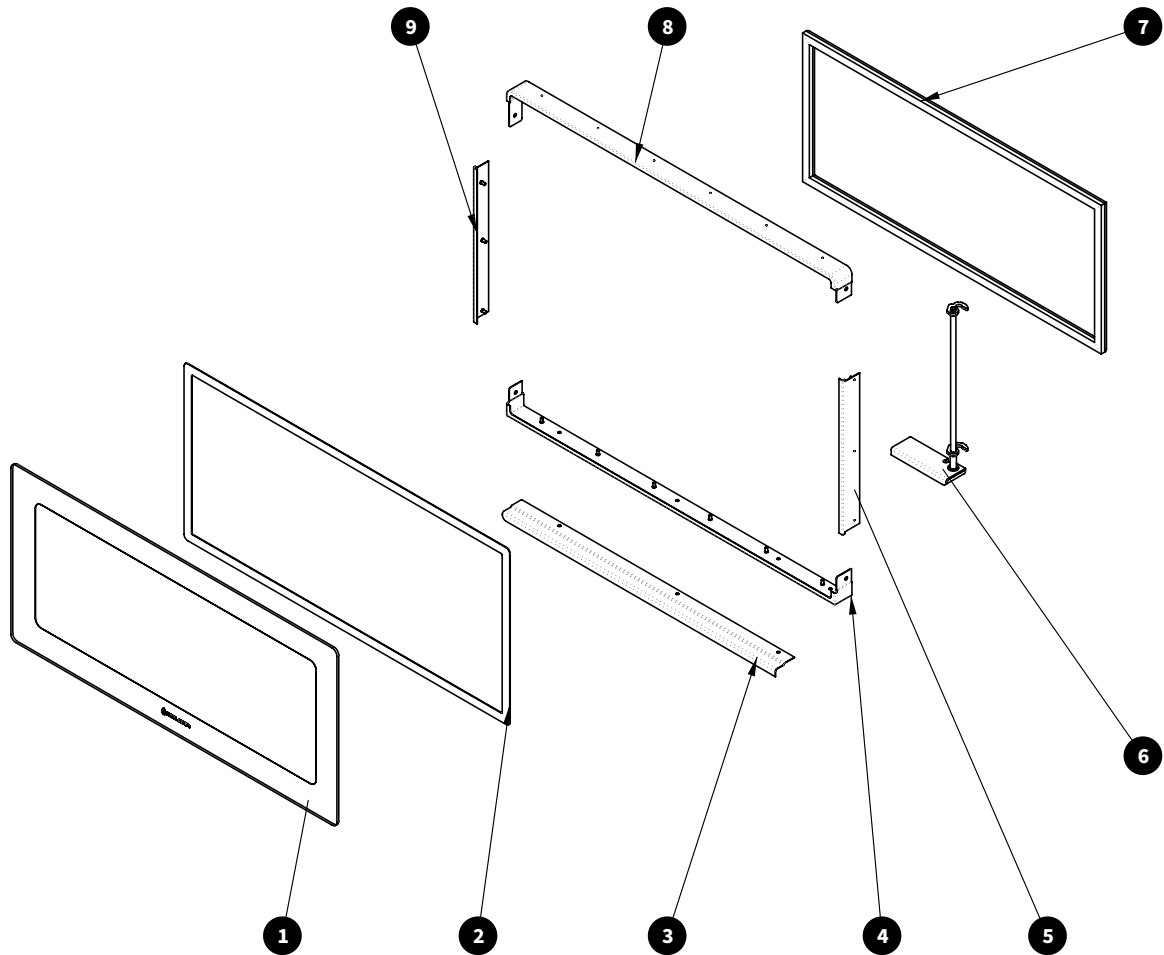

LEGEND	PART	QTY	KALORA PART NO.
1	Door Glass 871x410x5 KA URBAN LS	1	SG031000169
2	Glass Seal 20x 3mm x 2500mm	1	SG030400030
3	Door Fascia Kalora Urban LS	1	SG030700944
4	Bottom Glass Retainer Kalora Urban LS	1	SG030700940
5	RHS Glass Retainer Kalora Urban LS	1	SG030700942
6	Door Locking Mechanism KA Urban LS	1	SG031000170
7	Door Seal, Dia.20mm x 2250	1	SG030300026
8	Top Glass Retainer Kalora Urban LS	1	SG030700941
9	LHS Glass Retainer Kalora Urban LS	1	SG030700943

URBAN PT SPARE PARTS

SPARE PARTS

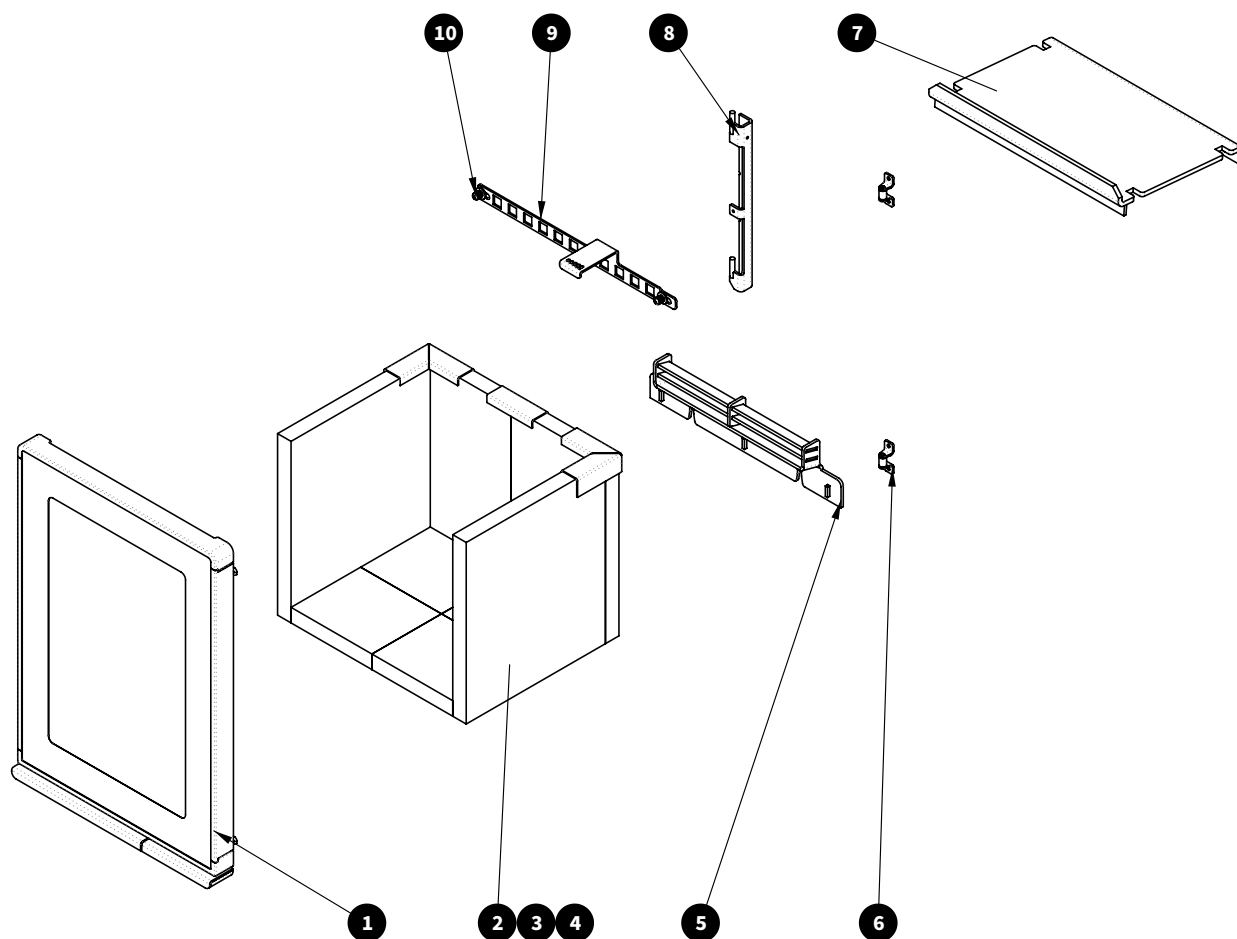

LEGEND	PART	QTY	KALORA PART NO.
1	Door Assembly Kalora Urban PT	1	SG031000182
2	Set Vermiculite Firebricks	1	SG030600040
3	Brick Retainer Corner	2	SPSTY111
4	Brick Retainer Rear	1	SPSTY112
5	Urban PT Ash Deflector	1	SG030700316
6	Door Latch on Body Black	2	SPMR512B
7	Urban Baffle Plate	1	SG030700911
8	Urban Door Hinge	1	SG030700500
9	Kalora, Urban PT, Air Slide	1	SG030700976
10	Kit Fasteners Air Slide	2	SG031300118

URBAN PT SPARE PARTScontinued

DOOR ASSEMBLY SPARE PARTS

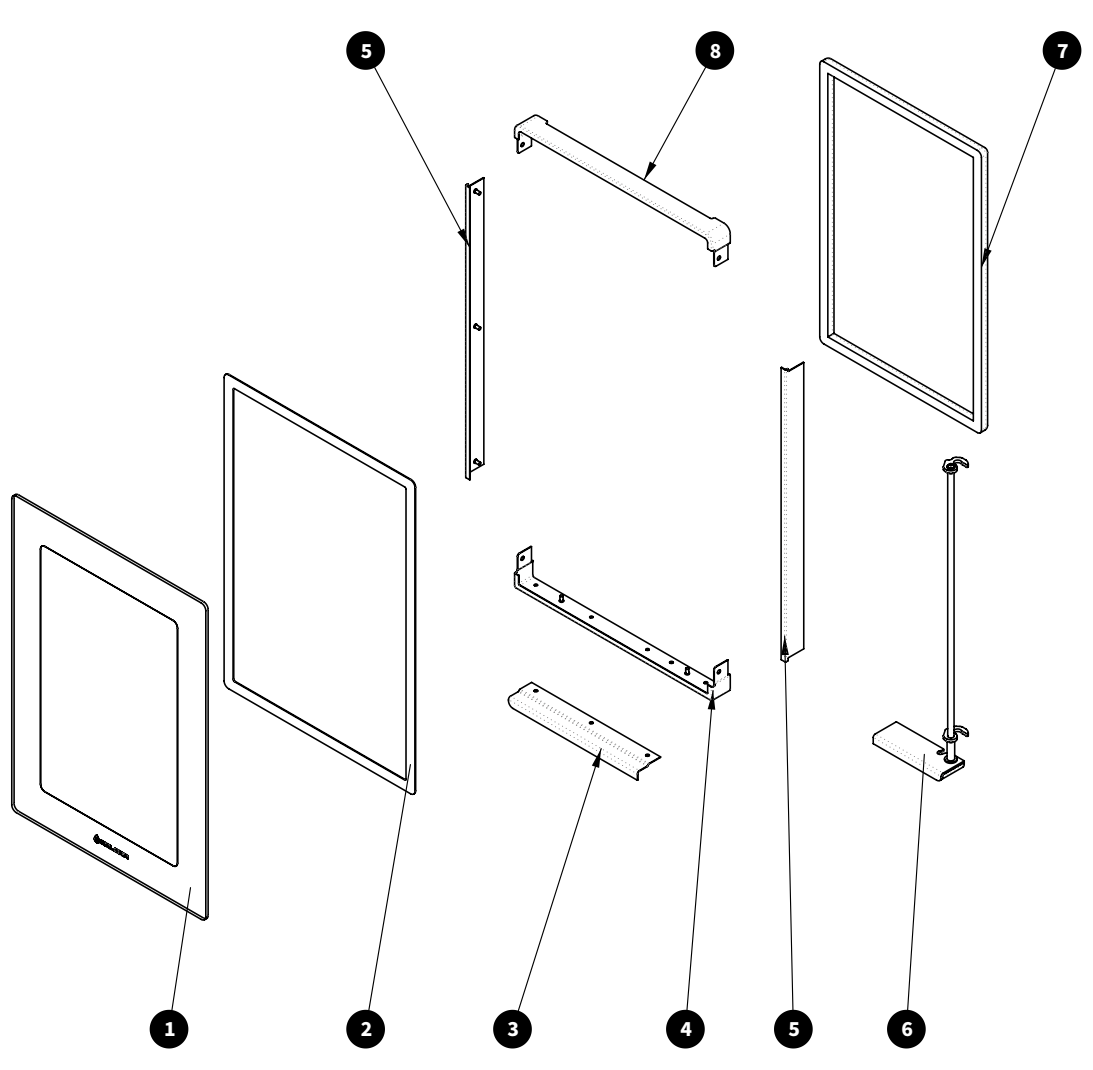

LEGEND	PART	QTY	KALORA PART NO.
1	Glass 432 X 610 Kalora Urban PT	1	SG031000156
2	Glass Seal 20 x 3mm x 2000mm	1	SG030400036
3	Door Fascia Kalora Urban PT	1	SG030701018
4	Bottom Glass Retainer Kalora Urban PT	1	SG030701016
5	Glass Retainer Side Kalora Urban PT	2	SG030700324
6	Kalora, Urban PT, Door Lock Assy	1	SG030700974
7	Door Seal, Dia. 20mm x 1760	1	SG030300023
8	Top Glass Retainer Kalora Urban PT	1	SG030701017

WARRANTY REGISTRATION CARD

MODEL NO:	SERIAL NO:		
PURCHASED BY:		PHONE:	
ADDRESS:			
EMAIL:		POSTCODE:	
PURCHASED FROM:		DATE:	
ADDRESS:			
INSTALLED BY:		DATE:	
INSTALLERS EMAIL:			
INSTALLERS NAME PRINT:		INSTALLERS SIGNATURE:	



REGISTER BY MAIL

Please complete this warranty card within 30 days of installation and return to:
Kalora Pty Ltd:
58 Access Way, Carrum Downs, Victoria, Australia, 3201.

Please keep your receipt as this will authenticate your warranty.

HEAD OFFICE

58 Access way,
Carrum Downs, Victoria,
Australia, 3201

+613 8579 5905
service@kalora.com.au
www.kalora.com.au





Kalora Pty Ltd
58 Access Way, Carrum Downs
Victoria 3201
Australia